

PRT-MF Series
ISO/IEC 14443A and Mifare
Access Terminals

Firmware v1.29

Rev. E



This document refers to the following products:

- *PRT12MF*
- *PRT12MF-BK*
- *PRT62MF*
- *PRT64MF*
- *PRT66MF*

Installation and Programming Guide

1. GLOSSARY OF TERMS	5
2. IMPORTANT NOTES	7
2.1. Compatibility Rules	7
2.2. About This Manual	7
3. GENERAL DESCRIPTION	8
3.1. Features	8
3.1.1. General	8
3.1.2. Terminal Mode (Online Mode)	8
3.1.3. Standalone Mode (Offline Mode)	8
3.2. Proximity Cards	9
3.3. Function Keys	10
4. OPERATING MODES	11
4.1. Terminal Mode	11
4.1.1. Wiegand Formats	11
4.1.2. Magstripe Formats	11
4.1.3. RACS Format	12
4.1.4. RS232, EPSO Protocol (9600, N, 8, 1)	12
4.1.5. RS232, Cards and Keys (9600, N, 8, 1)	12
4.1.6. RS232, Cards and PIN-s (9600, N, 8, 1)	13
4.2. Standalone Mode	13
4.2.1. Full Standalone Mode	13
4.2.2. Simple Standalone Mode	14
5. STANDALONE MODE	15
5.1. Users	15
5.1.1. Managing Users	15
5.1.2. User Identification	15
5.2. Door Unlocking	16
5.3. Facility Code	16
5.4. Arming Modes	16
5.4.1. Arming/Disarming Methods	17
5.5. Door Bell Function	19
5.6. Function Keys	19

5.7. Door Alarm	19
5.8. Tamper Alarm	20
5.9. Intruder Alarm.....	20
5.10. Duress Alarm.....	20
5.11. General Alarm.....	21
5.12. Events Recording	21
5.13. Real Time Clock	22
5.14. Timers	22
5.15. Optical and Acoustic Signals.....	23
5.16. Operation with XM-2 I/O Extension Module	24
5.17. Operation with Second PRT Series Reader.....	24
6. PROGRAMMING.....	26
6.1. Programming PRT-MF Readers without Keypad.....	26
6.1.1. Programming Through Multiple Readings of the Programming Card.....	26
6.1.2. Programming From The External Reader	27
6.2. Programming via Memory Card	27
6.2.1. Importing Configuration Settings from the Memory Card	27
6.2.2. Exporting Configuration Settings to the Memory Card.....	28
6.2.3. Importing Users Data from Memory Card	28
6.2.4. Exporting Users Data to Memory Card	28
6.2.5. Importing Installer Data from Memory Card.....	28
6.2.6. Exporting Installer Data to Memory Card.....	29
6.3. Memory Reset.....	29
6.3.1. Operating Modes	30
7. INSTALLER PROGRAMMING	34
7.1. Input/Output Functions.....	37
8. USER PROGRAMMING	40
8.1. User Programming Commands.....	40
9. PROGRAMMING FROM PC.....	43
9.1.1. Programming via RS232 COM port	43
9.2. Programming via RUD-1 interface	44
9.3. Firmware Upgrade	45

9.3.1. Firmware upgrade via RS232 COM port..... 45
9.3.2. Firmware upgrade via RUD-1 interface 45

10. INSTALLATION GUIDELINES..... 47

1 . G L O S S A R Y O F T E R M S

Door Release or Door Lock

Electric device used to lock/unlock a door. Typically it can be a door strike, solenoid lock or magnetic lock.

Identifier

The physical item or method which is used for identification of users. It can be a proximity card, a PIN code, a finger template etc. In some cases identifier may consist of two or more items required for a single identification procedure. For example when option **Card and PIN** is active then Identifier=Card+PIN.

Identification Mode

The method used for identification of users, it can be **Card or PIN, Card and PIN, Card only, PIN only** etc.

Memory Reset

The procedure which clears contents of device's memory and restores default (factory) settings.

PRT Series Readers

The PRT reader's family developed and manufactured by Roger.

Restart

The situation when device goes through the initialization procedure, the same as when it is powered up.

Roger Access Control System (RACS)

The access control system which consists of PR series access controllers developed and manufactured by Roger.

Access Control Unit (ACU)

The logic device which provides access control, usually it is an access controller.

XM-2 I/O Extension Module

The remote I/O extension module for RACS system. The XM-2 provides two NO/NC inputs and two relay outputs.

Full Standalone Mode

The operation mode in which reader autonomously controls a door passage. When operating in **Full Standalone Mode** the PRT-MF reader requires the remote XM-2 extension module, also in this mode it can operate with another (second) PRT series reader thus providing two-way passage control.

Simple Standalone Mode

The operation mode in which reader independently controls a door passage. When in **Simple Standalone Mode** the PRT-MF reader uses its internal I/O lines as general purpose I/Os but is not capable to operate with XM-2 I/O module and/or second PRT series reader.

RACS Interface

The electrical interface and addressable protocol developed by Roger. This interface is implemented in access readers and controllers manufactured by Roger. The RACS interface uses two communication lines (CLK and DTA) and proprietary communication protocol capable to address up to 16 devices.

EPSO Protocol

The addressable, half duplex, serial communication protocol developed by Roger. This protocol allows a host device (PC or controller) for direct control of the reader's hardware through the set of remote commands.

RARC Program

This program allows for programming and maintenance of the PRT series reader which are equipped with serial communication interface.

RogerISP Program

This program allows for firmware upgrade in access controllers and readers manufactured by Roger.

2 . I M P O R T A N T N O T E S

Note: The PRT-MF term refers to any type of access terminal from PRTxxMF series readers. It is clearly indicated when given information refers solely to specific device and is not valid for entire series.

The PRT-MF reader can be configured for several operating modes however the factory shipped unit is pre-configured for **RACS address ID=0**.

The PRT-MF reader can be programmed in following ways:

- Manually from the keypad located on primary reader (when available)
- Manually from the keypad located on secondary reader (when available)
- Manually by multiple readings of the so called **Programming Card**
- Remotely from PC computer with RARC program
- Manually by importing/exporting reader's settings from/to **Memory Card (*)**

(*) - **Memory Card** is an ordinary Mifare 4k proximity card or tag

If the reader is dedicated for operation in standalone mode (offline operation) and has to be programmed manually, it is necessary to program two special users into the reader: MASTER and INSTALLER, each of them can have card and/or PIN.

Any proximity card or tag can be programmed as MASTER or INSTALLER card. The same card can be programmed as MASTER or INSTALLER card to multiple readers. Whenever required (e.g. when stolen or lost) the new MASTER and INSTALLER cards can be programmed into given unit. No proximity cards are shipped with factory new unit - if necessary, installer must arrange and enroll them to the reader by himself.

Note: If after power up the LED SYSTEM  is lit it means that contents of reader's memory is corrupted. In this case reader must be initialized and programmed anew.

2.1. COMPATIBILITY RULES

Always check the firmware and hardware version for which manual is dedicated. Using wrong version of manual may cause that device will not behave as described in document.

Also, when you upgrade firmware in the reader assure that the new firmware is dedicated for given type of reader (it must be clearly stated that given firmware is dedicated for given type of product you have). Once the firmware is uploaded assure adequate manual for the upgraded device.

2.2. ABOUT THIS MANUAL

This manual is dedicated for all versions of PRT-MF readers: with keypad and without keypad. No matter if the PRT-MF readers have built-in keypad or not they represents the same logical functionality. The only difference between various types of PRT-MF series readers is limited to their mechanical construction, environment in which they can be installed and keypad which exist in limited number of PRT-MF readers. As the result of these the same configuration settings can be used to program various members of PRT-MF readers; also using RARC program configuration settings can be transferred (copied) between different members of PRT-MF family.

Theoretically, it is possible to program and use PIN codes and other functions related with keypad on PRT-MF readers which are not physically equipped with keypad however this has practical sense only when PRT-MF reader without keypad operates in **Full Standalone Mode** with another (second) PRT-MF reader which has built-in keypad. In such scenario users can utilize keypad functions (including PIN codes) on this second (slave) reader.

When PIN codes are programmed into reader without keypad it is obvious that they cannot be used on this individual reader however still they will exist in configuration settings of this particular unit and can be transferred from the reader to PC and then to another PRT-MF unit.

3 . G E N E R A L D E S C R I P T I O N

The PRT-MF readers have been designed for use in access control installations to enable user identification via ISO/IEC 14443A and Mifare proximity cards and/or PIN-s.

Readers can be configured for standalone operation (**Offline Mode**) or as an ordinary slave readers (**Online Mode**) connected to the external access control unit (ACU) supporting compatible data interface formats, this kind of operation is called **Terminal Mode**.

When configured for standalone operation PRT-MF reader independently (i.e. autonomously) controls the supervised door access point. For this mode reader offers two variants of installation: first of them uses the reader's built-in I/O signal lines as programmable inputs and outputs, the second one uses them for communication with external XM-2 I/O module and second (optional) PRT series reader. An access control installation containing two PRT readers (one at the entry and other at the exit side of the supervised door) enables two-way door control. Also, the system setup utilizing the XM-2 module provides higher level of security for the entire door access control system by separating its logical element (reader) from the relay which physically controls a door lock.

The PRT-MF reader configured for **Terminal Mode** works as a slave unit serving a sole purpose of reading cards/PIN-s then providing subsequent transmission of such collected data to host ACU for further processing. Reader offers several data transmission formats including popular Wiegand and Magstripe data protocols.

The PRT-MF reader can be also used as Mifare card writer however the standard version of RARC program which is distributed free of charge doesn't support card programming function. In order to use the reader as a card writer apply for special license available for the RARC program.

3.1. FEATURES

3.1.1. General

- ISO/IEC 14443A and Mifare sector reader/writer (*)
- Reads CSN, SSN and MSN (Mifare MAD)
- Up to 6 cm reading range
- Can operate with second PRT series reader as a slave unit
- Tamper switch
- Configurable as standalone access unit or slave reader
- Various operating temperatures (depends on particular reader)
- Outdoor and indoor installations (depends on particular reader)
- Connection via pig-tail or screw terminals (depends on particular reader)
- Programming and firmware upgrade through serial port
- RARC configuration program (for Windows)

(*) - the PRT-MF reader can be used as card programmer only when operating with licensed version of the RARC program (contact Roger for more details)

3.1.2. Terminal Mode (Online Mode)

- 26/32/32 reversed/34/42/66 bit Wiegand data formats
- Magstripe data format (ABA Track II emulation)
- RACS data output format (Roger format)
- RS232, EPSO protocol
- RS232, direct output of cards and keys
- RS232, direct output of cards and PIN-s
- Various options for transmission of PIN-s and keys
- LED control input
- BUZZER control input

3.1.3. Standalone Mode (Offline Mode)

- System settings stored in nonvolatile memory
- 120 indexed users with card and/or PIN-s

- User indexing (ID indexed user records)
- **Card or PIN or Card and PIN** identification
- Real time clock (100 year)
- Automatic winter/summer time change
- 1000 event log
- Built-in 1.5A relay output (PRT64MF and PRT66MF only)
- Support for door contact and exit button
- Door Alarm and Door Bell outputs
- Integration with the alarm system through I/O-s
- Two way door control (requires second PRT reader)
- Operation with XM-2 I/O extension module (**Full Standalone Mode**)

3.2. PROXIMITY CARDS

The PRT-MF was designed for ISO/IEC 14443A and Mifare proximity cards. Reader can be configured for reading of:

- CSN (Chip Serial Number)
- SSN (Card number kept in specified sector of a card)
- MSN (Card number kept in location addressable through MAD sector)

The CSN is returned without check sum. The SSN and MSN numbers are designated by sector number and block within specified sector. Also, for reading of a sector the adequate Access Key is required. For MSN number the MAD sector is deliberated using recommended type A key: A0A1A2A3A4A5. By default, reader uses MAD sector assigned by MSG organization to Roger company (Roger AID number: 5156). The PRT-MF returns last seven bytes (56 bits) of the card number. Card number is transmitted starting from the MSB to LSB (reverse order) or from LSB to MSB (normal order) and if required supplemented with leading zeros. By default reader uses "reverse order" for CSN number and "normal order" for MSN and SSN numbers.

Examples:

CSN number (Mifare 1K card, "reverse order")														
LSB														MSB
0x64	0xE2	0x11	0x46	BCC	Manufacturer Data									

Reader transmits: 0x00,0x00,0x00,0x46,0x11,0xE2,0x64

SSN or MSN number (reverse order)														
LSB														MSB
0x11	0x12	0x13	0x14	0x15	0x16	0x17	0x18	0x19	0x1A	...				

Reader transmits: 0x17,0x16,0x15,0x14,0x13,0x12,0x11

Cards reading procedure allows for three steps, in each step reader attempts to read the specified card number (CSN, SSN or MSN). Once the card number is successfully read the remaining steps are skipped.

The PRT-MF allows to read the CSN from following types of cards:

- Mifare 1K
- Mifare 4K
- Mifare Ultralight
- Mifare DESfire

The SSN and MSN numbers can be read from following Mifare cards:

- Mifare 1K
- Mifare 4K

Note: The PRT-MF supports MAD version 1 sectors only (01-15).

3.3. FUNCTION KEYS

Some of the PRT-MF series readers are equipped with two (e.g. PRT12MF) function keys: [F1]-marked with door bell icon and [F2] – marked with the light bulb icon. The function of each function keys depends on the reader's operation mode.

When in **RACS Mode**, pressing function key will cause transmission of the relevant code to the host controller which can further take adequate action (e.g. trigger door bell, light etc.). The host's reaction for function key always depends on its configuration.

When in **Wiegand** or **Magstripe** modes, pressing the F1/F2 causes following codes send over the output lines:

For Wiegand:

- F1=C hex
- F2=D hex

For Magstripe:

- F1=FF FF FF FF BC hex (1099511627708 dec)
- F2=FF FF FF FF BD hex (1099511627709 dec)

When PRT-MF operates in standalone mode (either **Full Standalone Mode** or **Simple Standalone Mode**) by default the F1/F2 keys work as door bell buttons however they can be eventually configured to control AUX1/AUX2 outputs. Also, in **Full Standalone Mode** function keys on secondary reader (if available) have the same functions as assigned for function keys on main reader even when the main reader has no keys at all.

4 . O P E R A T I N G M O D E S

There are two main modes of operation available for the PRT-MF reader:

- Terminal Mode (Online Mode)
- Standalone Mode (Offline Mode)

4.1. TERMINAL MODE

In this mode reader operates as a slave unit connected to the external access controller. In **Terminal Mode** reader transmits collected data (card or PIN) to the host for further processing. The PRT-MF offers following data transmission formats:

- Wiegand 26bit
- Wiegand 32bit, normal mode (from MSB to LSB)
- Wiegand 32bit, reverse order (from LSB to MSB)
- Wiegand 34bit
- Wiegand 42bit
- Wiegand 66bit
- Magstripe (ABA Track II emulation, also called Clock & Data)
- RACS (for communication with PR series of controllers from Roger)
- RS232, EPSO protocol (transactional protocol, reader responses commands received from the host)
- RS232, cards and individual keys
- RS232, cards and PIN-s

4.1.1. Wiegand Formats

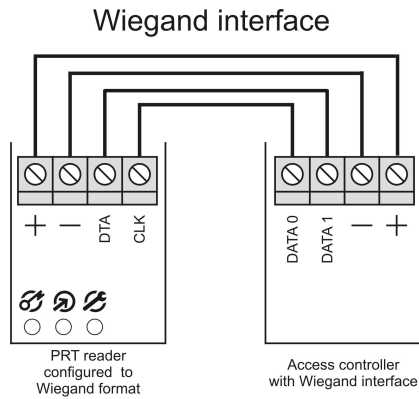

When employing **Wiegand** transmission format, data is sent to the host using sequences of short pulses transmitted over CLK and DTA lines. Depending on the selected version of the transmission format, the reader can send 26, 32, 34, 42 or 66 bits to the host.

Note: For card codes which require more bits than the number of bits available in the selected data transmission format, reader omits the most significant bits (MSB-s) of the card code. As a result transmission from a reader is not equal to the full card code.

In **Wiegand** format, a dual color LED STATUS lights steady in red, LED OPEN is controlled by IN1 while buzzer is controlled by IN2. Both inputs (IN1 and IN2) are triggered by shorting them to supply minus. In addition, whenever card is read or PIN is entered reader activates momentary LED SYSTEM and buzzer.

4.1.2. Magstripe Formats

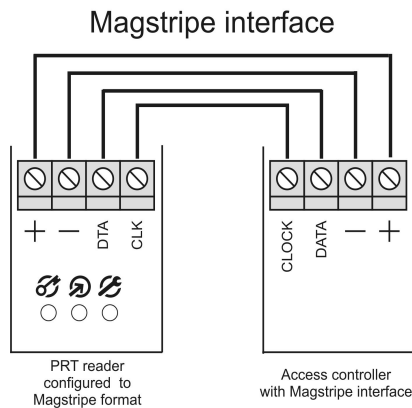

When employing **Magstripe** transmission format, data is transferred to the host using electric signal waves transmitted over the CLK and DTA lines. In **Magstripe** format a dual color LED STATUS lights steady in red, LED OPEN is controlled by IN1 while buzzer is controlled by IN2. Both inputs (IN1 and IN2) are triggered by supply minus. In addition, whenever card is read or PIN is entered reader activates momentary LED SYSTEM and buzzer. Card code is always transmitted as a whole number (no digits are lost).

4.1.3. RACS Format

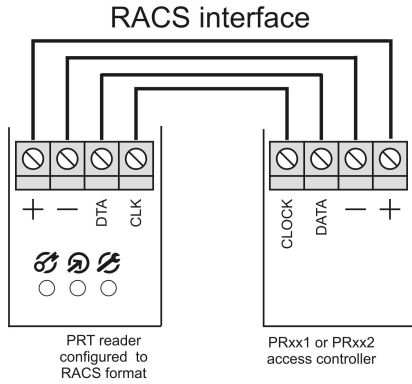

When employing **RACS** format, the PRT-MF unit communicates with the host via CLK/DTA lines. Unlike in the **Wiegand** and **Magstripe** formats, the PRT-MF unit using **RACS** format requires an individual address (ID=0...3) to be set during configuration of the reader. With **RACS** format, communications between the PRT-MF reader and the host is bilateral, this allows controller to monitor communication. The reader's LED-s and the buzzer are controlled by the host unit.

Note: When all LED-s are flashing it indicates that reader lost communication with the host unit.

When in **RACS** mode triggering of the IN1 disables reading of the card and keypad. This input can be used for temporary disabling of the reader. The IN2 is not used in **RACS** mode.

4.1.4. RS232, EPSO Protocol (9600, N, 8, 1)

When programmed to this protocol reader operates in transaction mode, i.e. responds only to external commands received through the RS232 port. The software developer or system integrator must incorporate EPSO protocol into the host device (usually PC or microcontroller) to communicate with the reader.

In **RS232 EPSO** reader answers only those data packets which come from the host unit and are addressed with reader's ID number (address). The **EPSO** protocol is the set of communication functions used to control the reader's hardware (inputs, outputs, LED-s, buzzer, keypad and reading of cards). The PRT-MF configured for **EPSO** mode acts as pure "terminal", it means that it strictly follows commands received from the host unit. The full description of **EPSO** protocol can be found on www.roger.pl.

4.1.5. RS232, Cards and Keys (9600, N, 8, 1)

Once the card is read or key is pressed reader outputs card/PIN data on TXD transmission line. Reader outputs card code as 10 hex number while each pressed key is transmitted separately as 2 hex coded ASCII characters.

Output format for cards				
STX	DATA	CR	LF	ETX
02 hex	10 hex digits coded ASCII	0D hex	0A hex	03 hex

Output format for keys				
STX	DATA	CR	LF	ETX
02 hex	2 hex digits coded ASCII	0D hex	0A hex	03 hex

Key codes														
Key	0	1	2	3	4	5	6	7	8	9	*	#	F1	F2
Code	F0	E1	D2	C3	B4	A5	96	87	78	69	5A	4B	3C	2D

4.1.6. RS232, Cards and PIN-s (9600, N, 8, 1)

Once the card is read or PIN code is entered reader outputs card/PIN data on TXD transmission line. Reader outputs card code as 10 hex digit number, PIN code is transmitted as whole number max. 16-digit long. Each pressed key is buffered and transmitted as a whole PIN when [#] key is pressed. The [#] key is treated as the end of the PIN.

Output format for cards				
STX	DATA	CR	LF	ETX
02 hex	10 hex digits coded ASCII	0D hex	0A hex	03 hex

Output format for PIN-s					
STX	DATA	#	CR	LF	ETX
02 hex	16 hex digits coded ASCII	23 hex	0D hex	0A hex	03 hex

The [*], [F1] and [F2] keys are transmitted in this format in the same way as PIN-s:

[*]: STX / 'A' / '#' / CR / LF / ETX

[F1]: STX / 'C' / '#' / CR / LF / ETX

[F2]: STX / 'D' / '#' / CR / LF / ETX

4.2. STANDALONE MODE

The PRT-MF reader offers two sub-modes for standalone operation:

- Full Standalone Mode
- Simple Standalone Mode

In both modes reader is capable of providing independent (i.e. autonomic) control of a single door passage.

4.2.1. Full Standalone Mode

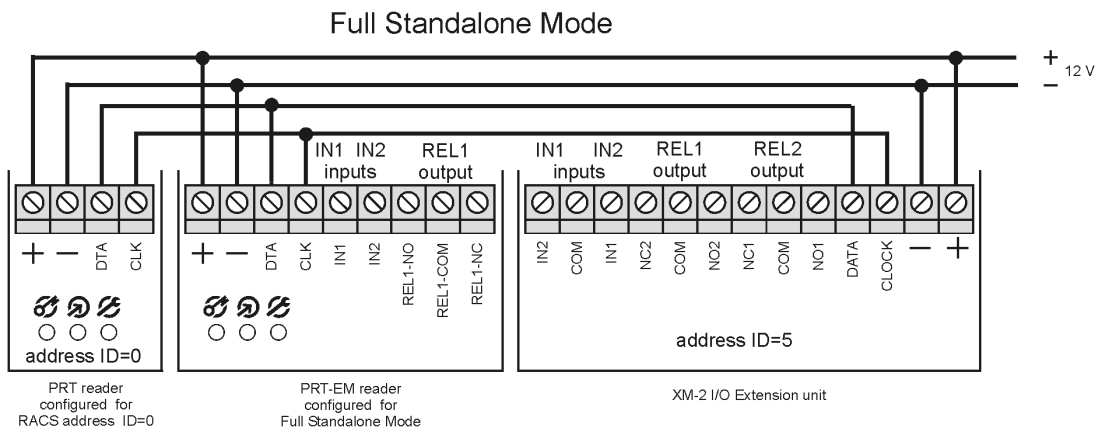

rcdr056

In this mode the CLK and DTA lines are used for communication with the remote XM-2 I/O extension module and the second (optional) PRT reader. The second reader enables two-way door control also it can be used for programming of the main reader. Each I/O line (no matter built-in or located on extension module) can be configured to various options. The **Full Standalone Mode** offers improved security, because it separates the reader from the attenuators which are used to control a door lock or other type of equipment.

Note: In **Full Standalone Mode** the optical and buzzer signals occur simultaneously on both readers. This rules is valid for programming mode and normal operation as well.

The maximum length of the cable run between the PRT-MF reader and the XM-2 module, or secondary PRT reader is limited to 150 m. For two-way door control the primary reader needs to be configured for **Full Standalone Mode** while the secondary one (slave) needs to be set for **RACS address ID=0**.

Note: For **Full Standalone Mode** the XM-2 I/O extension module has to be configured for address ID=5.

4.2.2. Simple Standalone Mode

Simple Standalone Mode

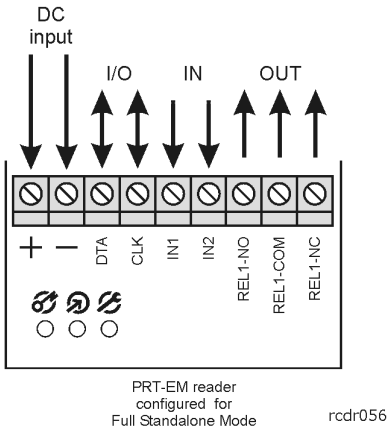

In this mode the CLK and DTA lines are used as programmable inputs or outputs while the IN1 and IN2 lines operates always as programmable inputs. The built-in REL1 operates as output only. Each I/O line can be configured to have one from several available functions.

Note: The CLK and DTA lines may operate either as inputs or outputs. The function assigned to CLK or DTA line automatically defines whether this line will operate as output or input. If configured to be an output, the CLK or DTA line operates as an open collector line capable to sink up to 150 mA. Such a current is usually sufficient to drive relay used for a door lock control. When necessary, both lines (CLK and DTA) can be configured to the same output function and connected together (shorted) for increased output current (max. 300mA).

5 . S T A N D A L O N E M O D E

5.1. USERS

When operating in standalone mode, the PRT-MF reader can register up to 120 users, each with a card and/or PIN (3-6 digits). Entry of a PIN code must be followed by the [#] which is required to mark the end of the PIN. Users can be identified by their PIN-s or cards. When the **Card and PIN option** is active, user must first present card and then subsequently enter PIN. The **Identification Mode** can be set individually for primary and secondary reader.

Note: In standalone mode reader uses full card code (40 bits).

The PRT-MF reader supports five types (classes) of users:

- MASTER
- INSTALLER
- NORMAL
- TOGGLE
- TOGGLE LTD

Types of Users	
MASTER	This user is allowed to enter User Programming mode and can have card and/or PIN.
INSTALLER	This user is allowed to enter Installer Programming mode only and can have card and/or PIN.
NORMAL	NORMAL users are solely authorized to unlock the controlled door, they can have card and/or PIN.
TOGGLE	TOGGLE users are authorized to unlock the controlled door and to switch reader between armed and disarmed mode, they can have card and/or PIN.
TOGGLE LTD	TOGGLE LTD (TOGGLE LIMITED) are solely authorized to switch reader between armed and disarmed modes, they can have card and/or PIN.

5.1.1. Managing Users

A new user can be registered in the reader using either the **Simple Programming** or **Full Programming** procedure.

The simple user programming procedure consists of programming of a PIN and/or card without specifying the ID number of a user to whom the programmed PIN/card will be assigned — as the result reader simply stores the PIN/card in the first unoccupied user's ID number.

The full user programming procedure requires specifying of the ID number for the new user being programmed which has to be followed by his PIN and/or card.

Note: When you program a user using the **Full Programming** procedure, later you will be able to selectively delete or modify him by using his ID number. If you program card/PIN using the **Simple Programming** procedure then to remove the given card/PIN from the reader you must present card to the reader or enter PIN code to be deleted, otherwise the only one method to remove them from the reader will be **Memory Reset** procedure which will clear all user data and configuration setting stored in the reader as well.

5.1.2. User Identification

In PRT-MF reader every user can be identified by card, PIN or both (when **Card and PIN** mode is active). The method which reader uses for user's identification depends on the actual **Identification Mode**. The PRT-MF enables following **Identification Modes**:

- **Card or PIN**, user must read his card or enter his PIN code
- **Card and PIN**, user must read his card and then subsequently enter his PIN code

Note: The **Identification Mode** can be programmed individually for primary and secondary reader (when operation in **Full Standalone Mode**).

5.2. DOOR UNLOCKING

In order to unlock a door user is required to use his identifier once (card and/or PIN). Whenever this happens, reader activates momentarily LED SYSTEM  (orange) and generates short confirmation beep. After successful identification reader unlocks a door for time defined by **Door Unlock Time**. Once opened door should be closed within **Door Open Timeout** – otherwise **Door Ajar** alarm will arise.

Note: The LED OPEN  is activated for the entire time when door lock output is active. When access to the room is denied, reader generates a long continuous beep.

The access to a room can be denied in following situations:

- When entered identifier (card/PIN) is not valid (unknown)
- When reader is armed and the option **Access disabled when reader armed** is active
- When entered identifier belongs to TOGGLE LTD class user
- When identification method wasn't full (e.g. user presented only card but **Card and PIN** mode was set active on the unit)

Note: With option **Access disabled when reader armed** the TOGGLE or TOGGLE LTD users may change reader's arming mode thus enabling or disabling access to a controlled door. Sometimes, armed and disarmed states can be thought as night and day modes.

5.3. FACILITY CODE

The **Facility Code** (also called **Site Code**) is a specific part of the entire card code which indicate group of card. For example when **Facility Code** is defined as 245 all cards which begin with "245" will comply with given **Facility Code** (e.g. 24532AB450, 245D4523AA, 2453456231 will comply while 12A4562432, 3214534522, 2353414422 will not).

When **Facility Code** option is active reader first searches if the card belongs to any user registered in the reader, if not, it verifies if this card comply with given **Facility Code**, when yes card is accepted as it was valid NORMAL user card, if not card is rejected.

Thanks to this feature reader may be used to grant access to large number of users which are not programmed individually into the reader but they have cards which comply with given **Facility Code**.

The whole card code may have up to 10 digits coded in HEX (13 digits coded in DEC). When defining the **Facility Code** installer must specify digit locations and their values in HEX format. For example when **Facility Code** was defined as "xxxx1ABxxx" every card which has the same pattern will be accepted by the reader regardless of the fact that it is not registered individually in reader's memory. The positions marked with x are not analyzed for compliance with **Facility Code**.

5.4. ARMING MODES

When in the standalone mode reader may stay in one of two arming modes: **Armed** or **Disarmed**. The actual arming mode of the reader is indicated on the dual color LED STATUS , which lights in red for **Armed** and green for **Disarmed**. Optionally, the actual arming mode can be indicated on the output line configured to option **[44]: Disarmed Mode** or **[45]: Armed Mode**. Such a configuration allows the output line to be used to arm/disarm of a connected alarm system or to switch on/off some other auxiliary system or device (e.g. heating, lights etc.). In general, the current arming mode of the reader have no influence on access rights unless the option **Access disabled when reader armed** is enabled. With this option activated, reader can only grant access when it works in disarmed mode.

Using the option mentioned above the TOGGLE and TOGGLE LTD users are allowed to enable or disable access to the supervised room through switching the reader between armed and disarmed modes. Also, it allows for automatic access locking upon the reader entering **Armed** mode.

Note: Although the arming modes of the reader were originally designed for integration with alarm system, they can be alternatively used for other control purposes which require on/off control method (light control, heating control etc). Upon powering on, reader automatically returns to the arming mode it was in before powered off. Also, the reader returns to its previous arming

mode when leaving the programming mode. After **Memory Reset** reader always enters **Armed** mode.

5.4.1. Arming/Disarming Methods

Note: The term "arming" should be understood here as the action effecting a switch into **Armed** mode, whereas the term "disarming" as a switch into **Disarmed** mode. The term "reader's arming mode" should be understood as actual state (either **Armed** or **Disarmed** mode) of the reader.

Reader can be armed/disarmed by means of TOGGLE/TOGGLE LTD users or by input line programmed to option **[24]: Arming/Disarming Key Switch**. When arming mode is controlled by input **[24]** reader changes its arming mode solely and unconditionally, according to the current state of this input.

Attempt to arm the reader by means of TOGGLE or TOGGLE LTD users is rejected in following situations:

- When input **[23]: Arming Disabled** is active (which might indicate that alarm system is not ready for arming)
- When input **[21]: Door Contact** is open (door is not closed)
- When input **[27]: Intruder** is open (intruder detected in area)

None of conditions listed above affects disarming of the reader – disarming is always unconditional.

Arming/Disarming by TOGGLE user card or PIN

The action needed by a TOGGLE user to change arming mode of the reader is to read twice (sequentially) the TOGGLE card or to enter twice (sequentially) the TOGGLE PIN code — however, when reader operates with the **Card and PIN** option, user needs to do both things for the first time (read a card and then subsequently enter his PIN) but with the second attempt he can use only one method (card or PIN).



Note: If access is not disabled by option **Access disabled when reader armed** then with first usage of TOGGLE user card/PIN reader automatically releases door lock and then waits for second (optional) usage of TOGGLE identifier to change current arming mode.

Arming/Disarming by TOGGLE LTD user card or PIN



TOGGLE LTD users may arm/disarm the reader simply by single use of his identifier (card, PIN or both when **Card and PIN** option is active).

Examples



Example 1: Rearming the reader by presenting a TOGGLE user card

- Read your TOGGLE user card
- Once accepted the reader grants you access (assuming that access is not disabled by option **Access disabled when reader armed**) and LED SYSTEM  starts blinking
- When LED SYSTEM  is blinking, once again present your TOGGLE card
- Reader will change its arming state and the LED STATUS  will change its color

Example 2: Rearming the reader by entering a TOGGLE user PIN code

- Key in the TOGGLE user PIN code, use [#] key to mark the end of a PIN
- Once accepted the reader grants you access and its LED SYSTEM  starts blinking
- When LED SYSTEM  is blinking, once again enroll your TOGGLE user PIN code
- Reader will change its arming state and LED STATUS  will change its color

Example 3: Rearming the reader by TOGGLE user when Card and PIN option is active

- Present your TOGGLE user card, LED OPEN  starts blinking which means that reader waits for TOGGLE PIN
- Enroll your TOGGLE user PIN
- Once accepted, reader will grant you access (assuming that access is not disabled by option **Access disabled when reader armed**) and LED SYSTEM  starts blinking
- When LED SYSTEM  is blinking, once again present your TOGGLE card or enter you TOGGLE PIN

- Reader will change arming mode and LED STATUS  will change its color

Arming/disarming by input

With input programmed to option **[24]: Arming/Disarming Key Switch** the current arming mode of the reader is solely controlled by the electrical state on this input. When line is open (not triggered) reader is forced to **Armed** mode, when closed (triggered) reader switches to **Disarmed** mode and remains in this state as long as line is active.

When reader’s arming mode is controlled through input **[24]** the usage of TOGGLE and TOGGLE LTD card/PIN is modified. In this case using TOGGLE/TOGGLE LTD card/PIN changes temporary (for approx. 8 sec.) current reader’s arming mode. If during this period the signal connected to input **[24]** will change its state (what would mean that controlled alarm system changed its arming mode as well) then the reader will remain in this new arming mode. In opposite, when during this limited 8 sec. period the input **[24]** will not change its state (what would mean that the alarm system did not changed its arming mode) reader will restore previous arming mode.

Note: When reader’s arming mode is controlled through input **[24]** the condition of the input **[23]: Arming Disabled** (if programmed) is limited to disable the use of TOGGLE/TOGGLE LTD user card/PIN and doesn’t affect process of arming and disarming.

Using reader for arming/disarming of the alarm system

There are several scenarios which can be used for integration between alarm system and the reader. Below, you will find the most complex way for integration between alarm system and the reader.

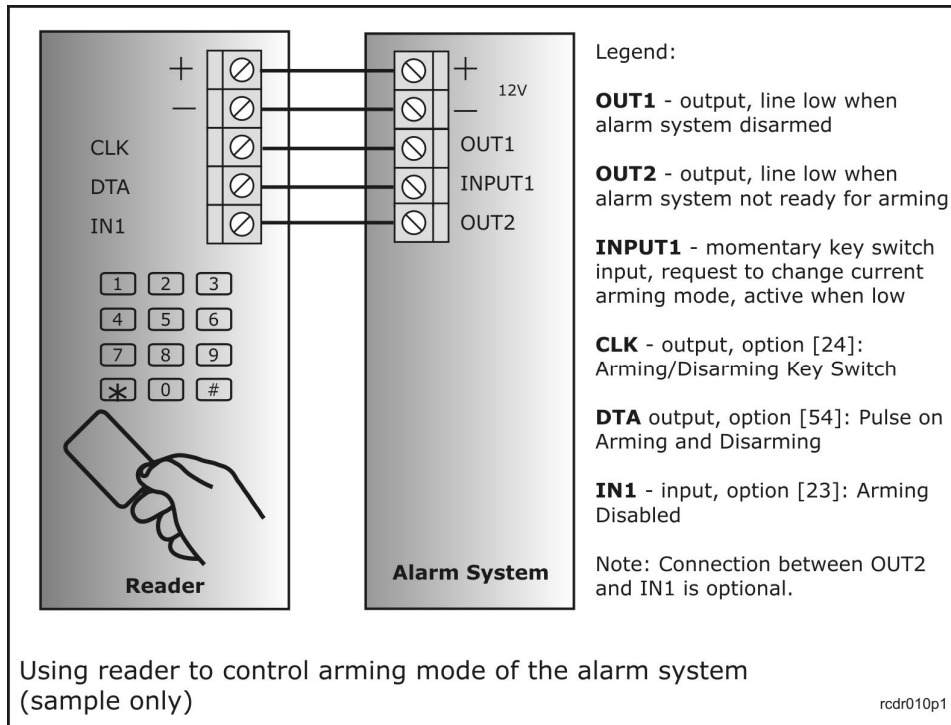

When using proposed configuration the current arming mode of the reader is controlled by the alarm system (output line from alarm system controls reader’s arming state), as a result reader always operates in the same arming mode as alarm system. Using TOGGLE or TOGGLE LTD card/PIN users can “request” the reader (and thus the alarm system as well) to change its current arming mode. Once the TOGGLE/TOGGLE LTD user changed temporary arming mode, reader waits approx. 8s for the alarm system to follow this change, if not reader restores previous arming mode however if alarm system will change its arming mode then reader will stay in this new arming mode as well. There are following benefits for this scenario:

- Whenever alarm system changes its arming mode reader follows this change
- The actual arming mode of the alarm system is presented on the reader’s LED STATUS 

- TOGGLE/ TOGGLE LTD users can change arming mode of the reader and the connected alarm system
- Alarm system can be controlled simultaneously from system keypads and from the reader (using the reader doesn't collide with alarm system keypads)

In order to implement this scenario alarm system should provide following signal lines:

- Latched output which indicates current arming mode of the alarm system (zone)
- Momentary input which when triggered requests change of current arming mode of the alarm system (zone)
- Latched output which indicates whether the alarm system (zone) is ready for arming or not

The output line which indicates that alarm system is ready for arming is not necessary and can be omitted, however when connected to reader's input **[23]: Arming Disabled** it will make that every attempt to arm the reader by TOGGLE/TOGGLE LTD users will be immediately rejected by the reader (reader will generate error sound and will not change its arming mode, even for temporary time).

Note: In some cases it can be essential to hide current arming state of the alarm system or reader therefore it is possible to use function which will conceal arming mode displayed by the reader (see option: **LED STATUS Masking** later in this document).

5.5. DOOR BELL FUNCTION

By default the **[F1]: Door Bell** or **[F2]: Light Bulb** keys operate as door bell buttons. When pressed they produce continues sound generated by the internal buzzer and optionally can trigger the **[47]: Door Bell** output (if programmed). Both indications last for 5 seconds and ceases automatically even when the key is still pressed. The door bell indication can be trigged either from primary or secondary reader. Also, the door bell can be triggered through the separate press of [#] key. This method is especially useful when F1 and F2 keys were programmed to other control function or doesn't exist on the particular device.

Note: The momentary press of [#] key which occur after entering PIN code doesn't produce door bell indication. Only separate, individual press of [#] key triggers door bell signaling.

5.6. FUNCTION KEYS

As mentioned above, by default, in standalone mode (no matter **Full** or **Simple Standalone Mode**) pressing the F1 or F2 key results in door bell signaling however this rule will be alternated if you program any output to one from following options: **[48]**, **[49]**, **[50]** or **[51]**.

If you program any output to option **[48]: AUX1 Momentary** or **[50]: AUX1 Toggle** then pressing of the F1 key will no longer trigger door bell but instead of this it will use to control corresponding output(s).

If you program any output to option **[49]: AUX2 Momentary** or **[51]: AUX2 Toggle** then pressing of the F2 key will no longer trigger door bell but instead of this it will use to control corresponding output(s).

Note: No matter if you press function key on primary or secondary reader system will react in the same way.

5.7. DOOR ALARM

The **Door Alarm** is a compound state which consists of one or more situations which are related to controlled door passage:

- Forced Entry
- Prealarm
- Door Ajar

The **Door Alarm** state can be signaled over the dedicated output **[46]: Door Alarm** and optionally on the internal buzzer (option: **Door Alarm indication on internal buzzer**). For indication of each particular type of alarm reader uses different signal modulation.

Door Alarm			
Event	Priority	Output modulation method	Alarm situation
Forced Entry	High	Sequence: Active - 4 sec., Pause - 4 sec. 	A door was open in unauthorized method. This state can be cleared by entering any valid identifier or disappears automatically after 3 minutes.
Prealarm	Medium	Sequence: Active - 1 sec., Pause - 1 sec. 	Detection of five consecutive usage of unknown card/PIN made within 5 minutes. Entering valid card/PIN clears fault attempt counter. During Prealarm state reader disables reading of cards and PIN-s thus blocking the users' identification for 5 minutes.
Door Ajar	Low	Sequence: Active - 1 sec., Pause - 1 sec., Active - 1 sec., Pause - 5 sec. 	Door not closed within Door Open Timeout . This state can be cleared by entering any valid identifier or disappears automatically after 3 minutes. Also, closing door immediately clears this alarm.
Note: Modulation methods are used for both, the output line and for internal buzzer as well (if configured for alarm indication).			

Note: The **Forced Entry** and **Door Ajar** alarms can occur only if the reader operates with a door open sensor ([21]: **Door Contact** input must be present).

5.8. TAMPER ALARM

This alarm is dedicated to indicate that reader's case is open or reader is detached from the place of installation. **Tamper Alarm** can arise either in armed or disarmed mode and is caused by active state on [26]: **Tamper** input. Once this alarm emerges reader starts counting **Tamper Timer** and activates outputs: [55]: **Tamper Alarm** and/or [57]: **General Alarm** (if programmed). During time period when **Tamper Timer** counts down reader disables [26]: **Tamper** input thus protecting the reader from multiply tamper alarms. The **Tamper Alarm** ceases automatically when **Tamper Timer** reaches the end or reader changes its arming mode.

5.9. INTRUDER ALARM

This alarm is dedicated to indicate that some intruder is penetrating area protected with sensor connected to reader's input [27]: **Intruder** or door was opened in unauthorized method (**Forced Entry**). The **Intruder Alarm** can arise in armed mode only. Once this alarm emerges reader starts counting **Intruder Timer** and activates outputs: [56]: **Intruder Alarm** and/or [57]: **General Alarm** (if programmed). During time when **Intruder Timer** counts down reader disables [27]: **Intruder** input thus protecting the reader from multiply intruder alarms. This alarm ceases automatically when **Intruder Timer** reaches the end or reader changes its arming mode.

5.10. DURESS ALARM

Reader can be configured to recognize and signal enroll of the PIN code under duress. When option **Duress Alarm** is enabled reader will treat PIN code as under duress when the last digit of the entered PIN code differs by +/- 1 from the original one. The **Duress Alarm** can be indicated on the output line ([60]: **Duress Alarm**) while the signaling time can be adjusted by **Duress Alarm**

Timer. This alarm ceases automatically when **Duress Timer** reaches the end or reader changes its arming mode.

5.11. GENERAL ALARM

This alarm is a sum of two separate alarms: **Tamper Alarm** and **Intruder Alarm** and is triggered whenever one of them arise. **General Alarm** can be indicated on the output line (**[57]: General Alarm**) while the signaling time can be adjusted by **General Alarm Timer**. This alarm ceases automatically when **General Alarm Timer** reaches the end or reader changes its arming mode.

5.12. EVENTS RECORDING

Reader is capable to record several types of events with time stamp. Events are stored in cyclic (FIFO) buffer – when entire event memory is occupied reader removes oldest events to releases space for the new ones to come. Totally, reader can record up to 1000 events.

List of events		
Code	Event Name	Description
100	Access granted	Access for the user (ID + name) has been granted
101	Access granted – Facility Code	Access has been granted for card with valid Facility Code
102	Access denied	Access for the user (ID + name) has been denied
103	Access denied – Facility Code	Access has been denied for card with valid Facility Code
200	Reader armed	Reader has been switched to Armed mode by user (ID + name)
201	Reader disarmed	Reader has been switched to Disarmed mode by user (ID + name)
104	Door unlocked	Door lock has been unlocked
105	Door relocked	Door lock has been re-locked
106	Door open	Door has been opened
107	Door closed	Door has been closed
108	Exit button	Input [22]: Exit Button has been triggered
202	Arming disabled	Arming has been disabled through input line [23]: Arming Disabled
203	Arming enabled	Arming has been re-enabled through input line [23]: Arming Disabled
204	Arming by input	Reader has been armed by input line [24]: Arming/Disarming Key Switch
205	Disarming by input	Reader has been disarmed by input line [24]: Arming/Disarming Key Switch
006	Summer time	Clock has been pushed backward by 1 hour
007	Winter time	Clock has been pushed forward by 1 hour
109	Door bell	Door bell indication triggered
300	Forced entry	Door opened in unauthorized way

304	Door ajar	Door open to long
301	Prealarm	Five consecutive attempts to enter wrong PIN or card within 5 minutes – Prealarm signaling started
112	Unknown card	The unknown card has been entered (card code)
113	Unknown PIN	The unknown PIN has been entered (PIN code)
003	User programming mode	Reader switched to User Programming mode
004	Installer programming mode	Reader switched to Installer Programming mode
005	Online mode	Reader switched to online communication mode with PC
000	Reader restarted	Reader passed through initialization procedure (the same as during power on)
001	Clock initialized	The internal clock of the reader has been initialized (cleared)
002	Clock changed	The internal clock of the reader has been programmed
302	Tamper Alarm	Reader entered Tamper Alarm state
303	Intruder Alarm	Reader entered Intruder Alarm state
305	Duress Alarm	Reader entered Duress Alarm state
999	Unknown event	Event code doesn't fit any known event – error in data

5.13. REAL TIME CLOCK

The PRT-MF is equipped with Real Time Clock (RTC) predefined for 100 year. This clock is used to append a time stamp to every event recorded by the reader. The RTC clock has not battery back-up so it resets to 2000-01-01 00:00 whenever power is off. When required, the RTC can be configured to switch automatically to winter or summer time.

When reader's Real Time Clock is unset (or lost due to lack of power supply) reader will continue its operation however it can be disabled till moment when clock will be re-set again (see function: **[78]** in Installer Programming).



5.14. TIMERS



Reader uses several timers, each timer is assigned to specific function and can be programmed in seconds or minutes.

ID	Timer	Defaults	Function
0	Door Unlock Time (00-99 sec./min.)	4 sec.	Defines time for which door lock will be released. This timer controls following outputs: [41]: Door Lock , [42]: Door Lock Exit , [43]: Door Lock Entry . Programming time 00s makes that timer counts down for unlimited period and it is stopped upon next access is granted again (toggle mode).
1	Door Open Timeout (00-99 sec./min.)	12 sec.	Determines time in which door should be closed. Door Open Timer starts from the moment when Door Lock Time has passed out.
2	AUX1 (00-99 sec./min.)	2 sec.	Defines duration time for output [50]: AUX1 Momentary . Programming timer to 00s makes that timer counts down for unlimited period till moment when reader changes it arming mode.

3	AUX2 (00-99 sec./min.)	2 sec.	Defines duration time for output [51]: AUX2 Momentary . Programming timer to 00s makes that timer counts down for unlimited period till moment when reader changes it arming mode.
4	Pulse on Arming (01-99 sec./min.)	2 sec.	Defines duration time for output [52]: Pulse on Arming .
5	Pulse on Disarming (01-99 sec./min.)	2 sec.	Defines duration time for output [53]: Pulse on Disarming .
6	Pulse on Arming/disarming (01-99 sec./min.)	2 sec.	Defines duration time for output [54]: Pulse on Arming/disarming output.
7	Tamper Alarm (00-99 sec./min.)	60 min.	Defines duration time for Tamper Alarm . Programming timer to 00s makes that timer counts down for unlimited period till moment when reader changes it arming mode.
8	Intruder Alarm (00-99 sec./min.)	60 min.	Defines duration time for Intruder Alarm . Programming timer to 00s makes that timer counts down for unlimited period till moment when reader changes it arming mode.
9	General Alarm (00-99 sec./min.)	3 min.	Defines duration time for General Alarm . Programming timer to 00s makes that timer counts down for unlimited period till moment when reader changes it arming mode.
10	Duress Alarm (00-99 sec./min.)	3 min.	Defines duration time for Duress Alarm . Programming timer to 00s makes that timer counts down for unlimited period till moment when reader changes it arming mode.
11	LED STATUS Masking (01-99 sec./min.)	20 sec.	Defines duration time for LED STATUS before it will switch to neutral mode when it lights up in red and green alternatively.

5.15. OPTICAL AND ACOUSTIC SIGNALS

LED Signals			
LED STATUS	LED OPEN	LED SYSTEM	Description
			
Green	—	—	Reader is disarmed.
Red	—	—	Reader is armed.
Red	ON	—	Reader is in User Programming mode.
Green	ON	—	Reader is in Installer Programming mode.
—	—	Flashing	During programming: reader is waiting for the user to enter the next part of the command or programming function.
		Flashing	During normal operation: reader is waiting for a TOGGLE user to enter his identifier once again in order to change reader's arming mode.

—	—	Single flash	A user identifier (Card or PIN) has been entered.
—	ON	—	The door lock is activated, this LED remains on as long as a door is unlocked.
—	Flashing	—	Reader is waiting for the PIN (when Card and PIN mode is valid).
	ON		Door is being unlocked (lock released).
—	—	ON	When LED SYSTEM  is lit and accompanied with short beep periodically repeated it means that either configuration memory is corrupted or MASTER and INSTALLER identifiers are not programmed yet. In this case reader must be totally reprogrammed. When LED SYSTEM  is lit and no sound is generated it means that error in firmware was detected. To fix this problem the proper firmware must be uploaded into the reader.

Acoustic Signals		
Signal	Symbol	Description
One long signal	-	Error - unknown identifier, access denied.
Three short beeps	* * *	Command successfully completed (OK signal).
Two short beeps	* *	Prompt signal, the reader is waiting for the next part of the command to be entered. This signal is intended to encourage the programmer to proceed with next programming steps.
Long beep continuously repeated	- - - - - ...	Reader has detected problem (either configuration memory is corrupted and reader must be reconfigured anew). This signal is accompanied by the steady lit LED SYSTEM  .
Legend: - long beep, * beep		

5.16. OPERATION WITH XM-2 I/O EXTENSION MODULE

In **Full Standalone Mode**, reader requires connection with XM-2 I/O extension module. Each input and output of the XM-2 can be programmed on the same basis as internal inputs and outputs of the reader. The XM-2 should be connected to the reader's CLK and DTA lines and must have address set to ID=5. The maximum distance between the reader and XM-2 extension module is limited to 150 m.

Note: The XM-2 module has two red LED-s which are intended to indicate triggering of corresponding relay output (REL1 or REL2) and one green LED which lights continuously when communication with host reader is working and blinking when broken.

5.17. OPERATION WITH SECOND PRT SERIES READER

In **Full Standalone Mode**, the main PRT-MF reader can operate with second PRT series reader, even when it works with another card standard (e.g. EM 125 KHz). The access system with two readers using different card technologies can be used for installations with two card technologies. The second PRT reader should be connected with main (primary) reader and configured for **RACS address ID=0**. The pair of two readers can be used for two way door control or for programming purpose when the main reader is not equipped with keypad. The maximum distance between primary and secondary PRT reader is limited to 150 m.

Note: The LED-s and buzzer on secondary reader mimics (imitate) the LED-s/buzzer on primary reader.

6 . P R O G R A M M I N G

The PRT-MF can be programmed if following ways:

- From the PC
- From the keypad located on the main reader
- From the keypad located on the external (secondary) reader
- Through multiple reading of the so called **Programming Card**

Preparing the Reader for Terminal Mode

If the unit is dedicated for **Terminal Mode** (slave operation), the only one programming step which is required is programming of the required operating mode. It can be done either manually during **Memory Reset** or remotely from PC.

Preparing the Reader for Standalone Mode

If the unit is dedicated for **Standalone Mode** (autonomic operation), installer must perform four programming steps:

1. Configuring the reader to either **Full** or **Simple Standalone Mode** and programming MASTER and INSTALLER cards and/or PIN-s (**Memory Reset**)
2. Configuring the reader for specific installation scenario (**Installer Programming**)
3. Programming cards and PIN-s for the users (**User Programming**)

Alternatively, reader can be connected to PC and programmed entirely from the RARC program.

6.1. PROGRAMMING PRT-MF READERS WITHOUT KEYPAD

The PRT-MF readers which are not equipped with keypad can be programmed in three ways only:

- From PC
- By multiple readings of the so called **Programming Card**
- From the keypad located on the second (slave) reader
- by importing settings via **Memory Card**

6.1.1. Programming Through Multiple Readings of the Programming Card

Though some PRT-MF readers are not equipped with keypad they can be programmed locally according to the same programming functions as readers with keypad. The difference in programming is so that instead of pressing certain keys (like you normally do when programming readers with keypad) you must emulate key pressing by multiple readings of the so called **Programming Card**. For example in order to emulate key [9] you must read **Programming Card** 9-times (simply present it to the reader and take it back 9-times) and then wait approx. 3 seconds for the reader to generate a confirmation signal (two beeps) which will mean that series of card readings were accepted as an equivalent of a single key press and the reader is now waiting for the next step of the programming procedure.

Use following cards as **Programming Cards**:

- In the **Installer Programming** use INSTALLER card
- in the **User Programming** use MASTER card
- in the **Memory Reset** procedure use any proximity card

Key	Emulation Method
[1]..[9]	Read card [N]-times where [N] is equal to programmed digit
[0]	Read Programming Card 10-times
[*]	Read Programming Card 11-times
[#]	Read Programming Card 12-times
Note: Each time you complete the sequence of multiple readings of the programming card wait for the reader to generate confirmation signal (two beeps) which will confirm that	

reader has accepted series of card readings as the equivalent of a single key press.

Example: In order to enroll following programming sequence [][1][0][ID][#] where ID=113 do following:*

1. [*]: Read 11-times programming card and then wait for two beeps
2. [1]: Read 1-time programming card and then wait for two beeps
3. [0]: Read 10-times programming card and then wait for two beeps
4. [1]: Read 1-time programming card and then wait for two beeps
5. [1]: Read 1-time programming card and then wait for two beeps
6. [3]: Read 3-times programming card and then wait for two beeps
7. [#]: Read 12-times programming card and then wait for two beeps

6.1.2. Programming From The External Reader

In this case the primary (main) reader must be first configured to **Full Standalone Mode** and then the secondary reader must be connected to the programmed unit. Once two readers are connected all programming procedures are made on keypad located on secondary (slave) reader. The LED/buzzer signals occur simultaneously on both readers (primary and secondary).

Note: The primary reader should be configured for **Full Standalone Mode** while secondary reader must be configured for **RACS address ID=0** and connected via CLK and DTA lines to primary reader (for details see wiring diagram for **Full Standalone Mode**). Also, both readers must have the same supply minus. It is not required to disconnect the XM-2 module from system being currently programmed.

6.2. PROGRAMMING VIA MEMORY CARD

The configuration settings of the reader can be *exported to* or *imported from* a special **Memory Card (M-Card)**. The **M-Card** is the standard Mifare 4k proximity card specially formatted by the RARC program for this purpose.

The entire settings of the reader can be divided into three parts:

- Configuration Settings
- User Settings
- Installer Settings





The **Configuration Settings** refers to all parameters programmed into a reader (card, PIN-s and all other data). The **Users Settings** refers to settings which are solely related with users (cards and PIN-s) while **Installer Settings** refers to the rest of reader settings (i.e. all configuration data except cards and PIN-s).

Reader settings can be exported to **M-Card** from a reader or from the RARC program. Also, the reader settings saved on the **M-Card** can be imported directly from **M-Card** to the reader or to the RARC program.

Note: The communication between RARC program and **Memory Card** can be provided through any PRT-MF series reader connected to the PC.





6.2.1. Importing Configuration Settings from the Memory Card

This procedure imports reader settings (Users Data + Installer Data) from the Memory Card.

- Switch power supply off
- Remove all connections from CLK and DTA lines
- Connect CLK to DTA
- Switch power on
- Wait till LED SYSTEM  is on
- While LED SYSTEM  is on disconnect CLK from DTA
- Wait till LED STATUS  starts blinking red
- While LED STATUS  is blinking red place M-Card very close to the front of the reader and keep it in this position
- Once LED STATUS  stops blinking remove the M-Card, reader will make restart and then will enter normal operation with new settings imported from the M-Card







6.2.2. Exporting Configuration Settings to the Memory Card

This procedure exports reader settings (Users Data + Installer Data) to the Memory Card.

- Switch power supply off
- Remove all connections from CLK and DTA lines
- Connect CLK to DTA
- Switch power on
- Wait till LED SYSTEM  is on
- While LED SYSTEM  is on disconnect CLK from DTA
- Wait till LED STATUS  starts blinking green
- While LED STATUS  is blinking green place M-Card very close to the front of the reader and keep it in this position
- Once LED STATUS  stops blinking remove the M-Card, reader will make restart and then will enter normal operation, the Configuration Settings from the reader were exported to the M-Card







6.2.3. Importing Users Data from Memory Card

This procedure imports Users Data (cards and PIN-s) from the Memory Card.

- Read the MASTER card or enter MASTER PIN, reader will enter User Programming Mode (LED STATUS  is red, LED OPEN  (green) is on)
- Read the M-Card (just close it to the reader and take it back), reader will generate OK signal and set LED SYSTEM  (orange)
- Wait till LED STATUS  starts blinking red
- While LED STATUS  is blinking red put the M-Card very close to the front of reader and keep it in this position
- When LED STATUS  is blinking red and accompanied with periodical beep reader is importing Users Data from the attached M-Card
- Once LED STATUS  stops blinking remove the card, reader will make restart and then will enter normal operation with new Users Data imported from the M-Card







6.2.4. Exporting Users Data to Memory Card

This procedure imports Users Data (cards and PIN-s) from the Memory Card.

- Read the MASTER card or enter MASTER PIN, reader will enter User Programming Mode (LED STATUS  is red, LED OPEN  (green) is on)
- Read the M-Card (just close it to the reader and take it back), reader will set LED SYSTEM  (orange)
- Wait till LED STATUS  starts blinking green
- While LED STATUS  is blinking put the M-Card very close to the front of reader and keep it in this position
- When LED STATUS  is blinking green and accompanied with periodical beep reader is exporting Users Data to the attached M-Card
- Once LED STATUS  stops blinking remove the M-Card, reader will make restart and then will enter normal operation, the Users Data from the reader were exported to the M-Card

6.2.5. Importing Installer Data from Memory Card







This procedure imports Installer Data (installer setup) from the Memory Card.

- Read the INSTALLER card or enter INSTALLER PIN, reader will enter Installer Programming Mode (LED STATUS  is green, LED OPEN  (green) is on)
- Read the M-Card (just close it to the reader and take it back), reader will set LED SYSTEM  (orange)
- Wait till LED STATUS  starts blinking red
- While LED STATUS  is blinking put the M-Card very close to the front of reader and keep it in this position
- When LED STATUS  is blinking and accompanied with periodical beep reader is importing Installer Data from the attached M-Card

- Once LED STATUS  stops blinking remove the M-Card, reader will make restart and then will enter normal operation with new Installer Data imported from the M-Card

6.2.6. Exporting Installer Data to Memory Card



This procedure exports Installer Data (installer setup) to the Memory Card.

- Read the INSTALLER card or enter INSTALLER PIN, reader will enter Installer Programming Mode (LED STATUS  is on and green, LED OPEN  (green) is on)
- Read the M-Card (just close it to the reader and take it back), reader will set LED SYSTEM  (orange)
- Wait till LED STATUS  starts blinking green
- While LED STATUS  is blinking put the M-Card very close to the front of reader and keep it in this position
- When LED STATUS  is blinking and accompanied with periodical beep reader is exporting Installer Data from the attached M-Card
- Once LED STATUS  stops blinking remove the M-Card, reader will make restart and then will enter normal operation, the Installer Data from the reader were exported to the M-Card

6.3. MEMORY RESET

The **Memory Reset** is a procedure which erases entire contents of the reader's memory (all cards, all PIN-s including MASTER and INSTALLER users) and causes the reader restores the factory-shipped default settings of configuration. Also, it enables of programming new reader's operating mode and MASTER and INSTALLERS identifiers as well (if required).

Memory Reset procedure:

1. Power down the unit (or place jumper on RST contacts).
2. Remove all connections from CLK, IN1 and RTS lines.
3. Make electrical bridge between CLK to IN1.
4. Restore power (or remove jumper from RST contacts), reader will generate continuous beep.
5. While LED OPEN  (green) is flashing and accompanied with continues sound disconnect CLK from IN1, after this step reader's memory is erased and filled with default values.
6. Wait till LED SYSTEM  will start flashing.
7. Enter three digits which will configure the reader for required operating mode, (with every entered digit reader generates two beeps).

Note: If you select code 030 or 031 which will configure the reader for standalone mode, it will be necessary to go to the next steps of **Memory Reset** procedure (steps: 8-12) but if you select any other code which will configure the reader for any non-standalone mode reader will automatically skip all remaining steps and will finish **Memory Reset** procedure and start normal operation.

8. Enter new MASTER PIN code (3-6 digits) followed by [#] key or skip this step and go to the next one.
9. Present any card to the reader — this card will become a new MASTER card, eventually (no matter if you have programmed MASTER PIN or not) you might skip this step by pressing [#] and go to the next one.
10. Enter a new INSTALLER PIN code (3-6 digits) followed by [#] key or skip this step and go to the next one.
11. Present another (second) card to the reader — this card will become a new INSTALLER card, eventually (no matter if you have programmed INSTALLER PIN or not) you might skip this step by pressing [#] and go to the next one.
12. Once the previous step is completed reader automatically ends the **Memory Reset** and switches to normal operation.

If you configure the reader for standalone operation mode but you don't program MASTER PIN/card you will not be able to enter **User Programming**. Also, if you configure the reader for standalone operation mode but you don't program INSTALLER PIN/card you will not be able to enter **Installer Programming**.

Note: When in step 7 you will select code which doesn't fit any available reader's operating mode or you stop entering any data for 20s reader will automatically leave the **Memory Reset** procedure.

6.3.1. Operating Modes

The factory new reader is pre-configured for **RACS address ID=0**. In order to change operating mode reader should be connected to PC or reprogrammed manually (**Memory Reset**).

Operating Modes		
Code	Operating mode	Description
000	Online mode: RACS address ID=0	Reader operates as a slave unit connected to the host controller that requires RACS data transmission format.
001	Online mode: RACS address ID=1	
002	Online mode: RACS address ID=2	
003	Online mode: RACS address ID=3	
010	Online mode: RS232, every pressed key transmitted separately	Reader is connected to the host through RS232 (9600,N,8,1) serial interface. Each key pressed is transmitted separately as HEX BCD digit. Key coding as below: Card output format: STX (02h) / Data (10 x hex digits coded ASCII) / CR (0Dh) / LF (0Ah) / ETX (03h) Key output format: STX (02h) / Data (2 x hex digits coded ASCII) / CR (0Dh) / LF (0Ah) / ETX (03h)
011	Online mode: RS232, PIN codes transmitted as whole numbers	Reader is connected to the host through RS232 (9600,N,8,1) serial interface. Each key entry is buffered, once the [#] key is pressed reader transmits entire PIN code as a single number max 16 digits long. The [#] key is treated as the end of PIN entry and not transmitted. Special keys [*, [F1] and [F2] are transmitted in the same way as entire PINs. Card output format: STX (02h) / Data (10 x hex digits coded ASCII) / CR (0Dh) / LF (0Ah) / ETX (03h) PIN output format: STX (02h) / Data (up to 16 hex digits coded ASCII) / '#' / CR (0Dh) / LF (0Ah) / ETX (03h) Special keys: [*]: STX / 'A' / '#' / CR / LF / ETX [F1]: STX / 'C' / '#' / CR / LF / ETX [F2]: STX / 'D' / '#' / CR / LF / ETX
020	Online mode: Magstripe	Reader operates as a slave unit connected to the host controller which requires Magstripe data transmission format, keys are not transmitted.
021	Online mode: Magstripe UNITEK	Reader operates as a slave unit connected to a host controller which requires Magstripe data transmission, keys transmitted as single digits, format is compatible with specification of UNITEK controllers (with transmission of PIN-s).
030	Offline mode: Simple Standalone Mode	Reader operates in standalone mode, the CLK and DTA lines serve as ordinary I/O lines.

031	Offline mode: Full Standalone Mode	Reader operates in standalone mode, the CLK and DTA lines are used for communication with remote XM-2 I/O and second (optional) PRT reader.
040	Online mode: RS232 EPSO v2 protocol	Reader is connected to the host through RS232 serial interface. The host exchanges data with the reader using EPSO v2 protocol .
10x	Online mode: 26 bit Wiegand	Reader operates as a slave unit connected to the host controller that requires specific Wiegand data transmission format.
11x	Online mode: 34 bit Wiegand	
12x	Online mode: 42 bit Wiegand	
13x	Online mode: 66 bit Wiegand	
14x	Online mode: 32 bit Wiegand (no parity)	
15x	Online mode: 32 bit Wiegand reverse (from LSB to MSB, no parity)	
<p>Note: For Wiegand data formats the third digit of the operating mode code (marked by "x") specifies the method which reader employs when transmitting PIN-s or keys. For details regarding methods of PIN transmission refer to table below.</p>		

PIN/Keys Transmission Options		
X	Description	Details
X=0	1-10 digits long PIN, transmitted in BCD format	Each key pressed is buffered in reader's memory; with a press of a [#] key reader transmits entire PIN code. The PIN code is transmitted as a BCD coded number.
X=1	1-12 digits PIN, transmitted in binary format	Each key pressed is buffered in reader's memory; with a press of a [#] key reader transmits entire PIN code. The PIN code is transmitted as a binary number.
X=2	Each key pressed is transmitted separately as 4-bit number plus 2 control bits	Each key pressed is immediately transmitted to the host controller as a sequence of 6 bits (EXXXXP) where XXXX represents the code of the pressed key supplemented by two control bits (E and P). The E represents the even bit calculated from the first half of a transmitted code where P represents the parity of a second half of the bit stream. This format is compatible with HID 5355 series readers, option "with parity". Key coding as in Table B (below).
X=3	Each key pressed is transmitted separately as 4-bit number	Each key pressed is immediately transmitted to the host controller as a sequence of 4 bits (XXXX) which represent the code of the pressed key, no control bits added. This format is compatible with HID 5355 series readers, option "without parity". Key coding as in Table B (below).
X=4	Each key pressed is transmitted separately as 8-bit number with parity	Each key pressed is immediately transmitted to the host controller as a sequence of 10 bits (EXXXXXXXXXP) where XXXXXXXX represents the code of the pressed key supplemented by two control bits (E and P). The E represents the even bit calculated from the first half of a transmitted code where P represents the parity of a second half of the bit stream. Key coding as in Table A (below).
X=5	Each key pressed is transmitted separately as a 8-bit number without parity bits	Each key pressed is immediately transmitted to the host controller as a sequence of 8 bits (XXXXXXXX) where XXXXXXXX represents the code of the pressed key supplemented by two control bits (E and P). The E represents the even bit calculated from the first half of a transmitted code where P represents the parity of a second half of the bit stream.



		Key coding as in Table A (below).
X=6	1-6 keys long PIN transmitted as Wiegand 26 bit stream with control bits	1-6 keys long PIN, each key represented by 4-bit long codes (key codes according to table B). Reader sends data after six keys are pressed or earlier when # key is pressed. Reader wait max ca. 15 seconds for each key press. Key's buffer is cleared if no keys have not been entered within ca. 15 seconds. Examples: Keys entered "1234#" – code transmitted "001234" Keys entered "123456" – code transmitted "123456"
X=7	1-4 keys long PIN transmitted as Wiegand 32 bit stream without control bits	1-4 keys long PIN, each key represented by 8-bit long codes (key codes according to table A). Reader sends data after four keys are pressed or earlier when # key is pressed. Reader wait max ca. 15 seconds for each key press. Key's buffer is cleared if no keys have not been entered within ca. 15 seconds. Examples: Keys entered "123#" – code transmitted "0123" Keys entered "123456" – code transmitted "123456"

Table A: 8-bit Key Coding		
Key	HEX	BIN
0	F0	11110000
1	E1	11100001
2	D2	11010010
3	C3	11000011
4	B4	10110100
5	A5	10100101
6	96	10010110
7	87	10000111
8	78	01111000
9	69	01101001
*	5A	01011010
#	4B	01001011
F1	3C	00111100
F2	2D	00101101

Table B: 4-bit Key Coding		
Key	ASCII	BIN
0	0	0000
1	1	0001

2	2	0010
3	3	0011
4	4	0100
5	5	0101
6	6	0110
7	7	0111
8	8	1000
9	9	1001
*	A	1010
#	B	1011

7 . I N S T A L L E R P R O G R A M M I N G

Use this mode to configure various functionalities of the PRT-MF reader. You enter this mode by reading of your INSTALLER card or entering your INSTALLER PIN. Once in this mode the LED OPEN  (green) turns on and LED STATUS  lights in green. The reader placed in this mode accepts following programming commands:

[53][EF] – Programming Function for CLK/REL1, EF=11, 21..27, 41..64, default: EF=41

This EF digits define the function for CLK line (when reader is configured for **Simple Standalone Mode**) or for REL1 output on XM-2 I/O module (when reader is configured for **Full Standalone Mode**). The CLK line can operate as input or output while REL1 always works as output. For I/O function codes see section **Input/Output Functions**.

Note: It is forbidden to program two or more inputs to the same function. This restriction is not valid for outputs. Reader indicates error when attempting to program two inputs to the same function.

[54][EF] – Programming function for DTA/REL2, EF=11, 21..27, 41..64, default: EF=44

This command sets the function for DTA line (when reader is configured for **Simple Standalone Mode**) or for REL2 output on XM-2 I/O module (when reader is configured for **Full Standalone Mode**). The DTA line can operate as input or output while REL2 always works as output.

[55][GH] – Programming function for IN1, GH=11, 21..27, default: GH=21

This command sets the function for IN1 input line located on the reader.

[56][GH] – Programming function for IN2, GH=11, 21..27, default: GH=11

This command sets the function for IN2 input line located on the reader.

[57][GH] – Programming function for IN1 on XM-2 expansion module, GH=11, 21..27, default: GH=22

This command sets the function for IN1 input located on the remote XM-2 I/O module.

[58][GH] – Programming function for IN2 on XM-2 expansion module, GH=11, 21..27, default GH=23

This command sets the function for IN2 input located on the remote XM-2 I/O module.

[59][J] – Programming Identification Mode for primary reader, J=0..1, default: J=0

This command sets the **Identification Mode** for the primary reader. Program J=0 for **Card or PIN** mode or J=1 for **Card and PIN** mode.

[60][J] – Programming Identification Mode for secondary reader, J=0..1, default: J=0

This command sets the **Identification Mode** for the secondary (external) reader. Program J=0 for **Card or PIN** mode or J=1 for **Card and PIN** mode.

[61][J] – Programming option “Door Alarm indication on internal buzzer”, J=0..1, default: J=0

When J=0 reader will not signal **Door Alarm** on internal buzzer, when J=1 **Door Alarm** will be signaled on output (if programmed) and buzzer as well.

[62][J] – Programming option “Access disabled when reader armed”, J=0..1, default: J=0

When J=0 reader will grant access no matter if it is in armed or disarmed mode, setting J=1 will make that access can be granted only in disarmed mode.

[63][S][KL] – Programming AUX1 Timer, S=0..1, KL=00..99, default: S=0, KL=02

The **AUX1 Timer** defines triggering time for **AUX1 Momentary** output. When S=0 and KL=00 output will be triggered for unlimited time - till moment when reader will change its arming mode again. Program S=0 for seconds or S=1 for minutes. Setting S=1 and KL=00 is forbidden.

[64][S][KL] – Programming AUX2 Timer, S=0..1, KL=00..99, default: S=0, KL=02

The **AUX2 Timer** defines triggering time for **AUX2 Momentary** output. When S=0 and KL=00 output will be triggered for unlimited time - till moment when reader will change its arming mode again. Program S=0 for seconds or S=1 for minutes. Setting S=1 and KL=00 is forbidden.

[65][J] – Programming option “Enable Card/PIN reading when in Prealarm”, J=0..1, default: J=0

When J=0 option is cleared and reader will not read cards nor PIN-s when it is in **Prealarm** state, when J=1 reader will allow to use cards/PIN-s during **Prealarm** state.

[66][J] – Programming option “Unlimited duration of Door Ajar alarm”, J=0..1, default: J=0

Setting J=0 will make that **Door Ajar** alarm will be automatically cleared after 3 minutes or immediately with valid card/PIN entered, setting J=1 will make that **Door Ajar** will last as long as door will be open.

[67][EF] – Programming function for built-in REL1 output, EF=11, 41..64, default: EF=46

This command sets the function for built-in REL1 output.

Note: The REL1 built-in output is available on PRT64MF and PRT66MF readers only.

[68][S][KL] – Programming Tamper Alarm Timer, S=0..1, KL=00..99, default: S=1 KL=60

This timer defines duration time for **Tamper Alarm**. When S=0 and KL=00 alarm time will be unlimited - till moment when reader changes its arming mode. Program S=0 for seconds or S=1 for minutes. Setting S=1 and KL=00 is forbidden.

[69][S][KL] – Programming Intruder Alarm Timer, S=0..1, KL=00..99, default: S=1 KL=60

This timer defines duration time for **Intruder Alarm**. When S=0 and KL=00 alarm time will be unlimited - till moment when reader changes its arming mode. Program S=0 for seconds or S=1 for minutes. Setting S=1 and KL=00 is forbidden.

[70][S][KL] – Programming General Alarm Timer, S=0..1, KL=00..99, default: S=1 KL=03

This timer defines duration time for **General Alarm** output. When S=0 and KL=00 alarm time will be unlimited till moment when reader changes its arming mode. Program S=0 for seconds or S=1 for minutes. Setting S=1 and KL=00 is forbidden.

[71][S][KL] – Programming Door Unlock Time, S=0..1, KL=00..99, default: S=0 KL= 04

The KL digits define time (is seconds when S=0 or in minutes when S=1) for which the reader will unlock a door when access will be granted. When S=0 and KL=00 reader unlocks a door for unlimited time - till a moment when access is granted again. If reader operates with door open sensor (input **[21]: Door Contact**) door is automatically re-locked when door sensor indicates corresponding door is closed again regardless of fact the **Door Unlock Time** did not pass by. Setting S=1 and KL=00 is forbidden.

[72][S][KL] – Programming Door Open Timeout, S=0..1, KL=00..99, default: S=0 KL=12

The KL digits define time (is seconds when S=0 or in minutes when S=1) for which door should be closed otherwise **Door Ajar** alarm will arise. The **Door Open Timeout** starts immediately after **Door Unlock Time** is passed by. If the reader operates without door contact sensor then **Door Open Timeout** is ignored and has no effect on reader's operation. Setting S=1 and KL=00 is forbidden.

Note: Setting S=0 and KL=00 will set unlimited open time thus will disable indication of a **Door Ajar** alarm.

[73][S][KL] – Programming Duress Alarm Timer, S=0..1, KL=00..99, default: S=1 KL=03

This timer defines duration time for **Duress Alarm**. When S=0 and KL=00 alarm time will be unlimited - till moment when reader changes its arming mode. Program S=0 for seconds or S=1 for minutes. Setting S=1 and KL=00 is forbidden.

[74][S][KL] – Programming LED STATUS Masking Timer, S=0..1, KL=00..99, default: S=0 KL=00

This timer defines time for which LED STATUS will be active after since the moment when arming mode was changed. Program S=0 for seconds or S=1 for minutes. Setting S=0 and KL=00 or S=1 and KL=00 is forbidden.

Note: This timer has been used only when LED STATUS Masking function is activated.

[75][L] – Programming keypad backlight level, L=0..5, default: L=3

The L digit defines keypad backlight level. Program: L=0 for 0% (backlight is off), L=1 for 20%, L=2 for 40%, L=3 for 60%, L=4 for 80% or L=5 for 100% (maximum backlight).

Note: This function is available of PRT64MF reader only.

[76][L] – Programming buzzer loudness level, L=0..5, default: L=3

The L digit defines buzzer loudness level. Program: L=0 for 0% (sound is off), L=1 for 20%, L=2 for 40%, L=3 for 60%, L=4 for 80% or L=5 for 100% (maximum sound).

Note: This function is available of PRT62MF, PRT64MF and PRT66MF readers only.

[77][L] – Programming LED STATUS Masking function, L=0..1, default: L=0

When L=0 LED STATUS continuously indicates current arming mode of the unit. When L=1 LED STATUS is normally in neutral mode (sequentially switches from green to red and vice versa however whenever arming mode is changed or unit is restarted it lights up for time defined by LED STATUS timer and then switches to neutral mode again.

Note: Use this function in case you want to keep secret current arming mode of the unit.

[78][L] – Programming Real Time Clock Control option, L=0..1, default: L=0

When L=0 reader continues normal operation even when reader's clock is unset or lost. When L=1 reader stops its normal operation however user can use keypad to set clock and restore normal reader operation.

Note: When option is active and clock is unset or lost, all LED-s are pulsing and reader stops its normal operation. In order to restore normal operation set the clock either manually or from PC.

[79][D] – Programming Duress function, D=0..1, default: D=0

When D=0 reader will not either recognize nor signal enroll of PIN under duress. When D=1 entering a valid PIN code with last digit modified by +/-1 will be treated as under duress and will cause signaling on output line (when programmed).

[80] [SSWW] – Programming Winter/Summer time change

SS: Day in March when time is changed from Winter to Summer (clock is moved from 2:00 to 3:00). Setting SS=00 deactivates automatic time change while programming SS=99 makes device will change Winter/Summer time on last Sunday of March.

WW: Day in October when time is changed from Summer to Winter (clock is moved from 3:00 to 2:00). Setting WW=00 deactivates automatic time change while programming WW=99 makes device will change time on last Sunday of October.

[81][PIN][#][Card] – Programming new MASTER user

Programs PIN and card for MASTER user. Optionally, program [81][PIN][#][#] to omit card programming or [81][Card] to omit PIN programming.

[82][PIN][#][Card] – Programming new INSTALLER PIN and/or card

Programs PIN and card for Installer user. Optionally, program [82][PIN][#][#] to omit card programming or [82][Card] to omit PIN programming.

[83][S][KL] – Programming “Pulse on Arming” timer, S=0..1, KL=01..99, default: S=1 KL=03

This timer defines duration time for pulse generated on [52] output. When S=0 and KL=00 pulse time is unlimited and will last till moment when reader changes its arming mode. Program S=0 for seconds or S=1 for minutes. Setting S=1 and KL=00 is forbidden.

[84][S][KL] – Programming “Pulse on Disarming” timer, S=0..1, KL=01..99, default: S=1 KL=03

This timer defines duration time for pulse generated on [53] output. When S=0 and KL=00 pulse time is unlimited and will last till moment when reader changes its arming mode. Program S=0 for seconds or S=1 for minutes. Setting S=1 and KL=00 is forbidden.

[85][S][KL] – Programming “Pulse on Arming/Disarming” timer, S=0..1, KL=01..99, default: S=1 KL=03



This timer defines duration time for pulse generated on [54] output. When S=0 and KL=00 pulse time is unlimited and will last till moment when reader changes its arming mode. Program S=0 for seconds or S=1 for minutes. Setting S=1 and KL=00 is forbidden.

[#] - Exit from Installer Programming mode

Reader leaves **Installer Programming** mode and returns to normal operation (either Armed or Disarmed) depending on the state it was before.

Note: If you don't press any key within 3 min. reader will automatically leave the **Installer Programming** mode.



7.1. INPUT/OUTPUT FUNCTIONS

Input/Output Functions		
Code	Name	Description
11	Line Off	Line is disabled and reader ignores electrical states on this line.
21	Door Contact	Input, when shorted with supply minus indicates that controlled door is closed.
22	Exit Button	Input, shorting this line with supply minus triggers [41]: Door Lock and [42]: Exit Door Lock outputs (when programmed) for time specified by Door Unlock Time . This input doesn't activate [43]: Entry Door Lock .
23	Arming Disabled	Input, as long as line is shorted with supply minus reader disables TOGGLE and TOGGLE LTD user from switching the reader into Armed mode.
24	Arming/Disarming Key Switch	Input, when line is shorted to supply minus reader switches <u>unconditionally</u> to Disarmed mode, when line is open reader returns and stay in Armed mode.
25	LED STATUS	Input, when programmed it controls LED STATUS  and this LED no longer presents current arming mode of the reader. When line is shorted to supply minus LED STATUS  lights in green, when open lights in red.

26	Tamper	Input, normally closed, opening this input (no matter in Armed mode or in Disarmed mode) will start Tamper Alarm and General Alarm .
27	Intruder	Input, normally closed to supply minus, opening this input during Armed mode will start Intruder Alarm and General Alarm .
28	Buzzer Control	Input, when shorted with supply minus activates buzzer.
29	LED OPEN Control	Input, when shorted with supply minus activates LED OPEN.
41	Door Lock	Output, whenever access is granted (no matter from primary or secondary or through exit button), this output is triggered for time specified by Door Unlock Time .
42	Exit Door Lock	Output, triggered whenever access is granted from primary (main) reader or by triggering of the [22]: Exit Button input, once triggered it goes on for time specified by Door Unlock Time . It is not activated when access is granted from secondary reader. This output is dedicated for rotary gates when two opening outputs (for clockwise and anticlockwise movement) are necessary
43	Entry Door Lock	Output, triggered whenever access is granted from secondary (external) reader, this output goes on for time specified by Door Unlock Time . It is not activated when access is granted from primary reader or from exit button input. This output is dedicated for rotary gates when two opening outputs (for clockwise and anticlockwise movement) are necessary.
44	Disarmed Mode	Output, line remains active as long as reader is disarmed.
45	Armed Mode	Output, line remains active as long as reader is armed.
46	Door Alarm	Output, line is used to indicate Door Alarm and is modulated according to detected type of alarm, when more than one alarm exists output signals alarm with the highest priority.
47	Door Bell	Output, signals door bell for approx. 5 seconds.
48	AUX1 Toggle	Output, whenever F1 is pressed this output switches to opposite state regardless of the setting of AUX1 Timer .
49	AUX2 Toggle	Output, whenever F2 is pressed this output switches to opposite state regardless of the setting of AUX2 Timer .
50	AUX1 Momentary	Output, line is activated for predefined time when F1 key is pressed. The activation time is specified by AUX1 Timer . When AUX1 Timer is set to 00s output it activated for unlimited time - till moment when reader changes its arming mode again.
51	AUX2 Momentary	Output, line is activated for predefined time when F2 key is pressed. The activation time is specified by AUX2 Timer . When AUX2 Timer is set to 00s output it activated for unlimited time - till moment when reader changes its arming mode again.
52	Pulse on Arming	Output, line is activated for predefined time whenever reader is switched to armed mode. Activation time is defined by Pulse on Arming Timer .
53	Pulse on Disarming	Output, line is activated for predefined time whenever reader is switched to disarmed mode. Activation time is defined by

		Pulse on Disarming Timer.
54	Pulse on Arming and Disarming	Output, line is activated for predefined time whenever reader changes its arming mode. Activation time is defined by Pulse on Arming/Disarming Timer .
55	Tamper Alarm	Output, line is triggered in the moment when Tamper Alarm arise. Output remains active for time defined by Tamper Timer however whenever reader changes its arming mode this output is immediately cleared. When corresponding timer is set to 00s output it activated for unlimited time - till moment when reader changes its arming mode again.
56	Intruder Alarm	Output, line is triggered in the moment when Intruder Alarm arise. Output remains active for time defined by Intruder Timer however whenever reader changes its arming mode this output is immediately cleared. When corresponding timer is set to 00s output it activated for unlimited time - till moment when reader changes its arming mode again.
57	General Alarm	Output, line is triggered in the moment when Tamper Alarm or Intruder Alarm arise. Output remain active for a time defined by General Alarm Timer however whenever reader changes its arming mode this output is immediately cleared. When corresponding timer is set to 00s output it activated for unlimited time - till moment when reader changes its arming mode again.
58	Door Unlock Timeout	Output, line is triggered in the moment when access is granted and remains active for the entire time when door lock is released (same as Door Unlock Time).
59	Door Open Timeout	Output, line is active for the entire time when reader waits for a door to become closed (same as Door Open Timeout).
60	Duress Alarm	Output, line is triggered in the moment when Duress Alarm arise. Output remains active for time defined by Duress Alarm Timer however whenever reader changes its arming mode this output is immediately cleared.
61	LED STATUS Timer	Output, line is triggered in the moment when reader changes its arming mode and remains active as long as LED STATUS presents actual arming mode.
64	Door Lock Inverted	Output, same as [41]: Door Lock but inverted (normally this output is on, when triggered it goes off).

8 . U S E R P R O G R A M M I N G

Use the **User Programming** mode to manage users registered in the reader (add and delete cards and PIN-s). To enter this mode let the reader read one time your MASTER card or enter your MASTER PIN. When in **User Programming** mode, LED OPEN  (green) is on and LED STATUS  lights in red.

In **User Programming** mode you have set of programming commands. When you begin to enter any of them, LED SYSTEM  starts flashing and it keeps flashing until this command has been correctly completed. If reader receives no valid input (entries) for more than 20 sec. (between the successive steps of the command sequence), it automatically ends the command sequence, however it still remains in **User Programming** mode so that you may return to any user programming command or you may press [#] to exit this programming mode, alternatively you may wait ~3 min. for the reader to leave **User Programming** mode automatically.

Note: Each user ID index consists always of three digits to form ID numbers ranging 000–119. In case you assign a new user the ID that is already occupied by some other user, this will remove the older one from the memory.

8.1. USER PROGRAMMING COMMANDS

Note: Any attempt to program an already registered card or PIN will be indicated as a programming error.

[11][PIN][#] – Add NORMAL user with PIN

The new NORMAL user added with this function is stored in unoccupied (free) location of the memory and his ID is unknown.

[12][Card 1][Card 2]...[Card N][#] – Add multiple NORMAL users with cards

The reader indicates each successful card reading with an acoustic prompt signal (two beep-s) for the next one to follow. This function is ended automatically if no card is presented within 20 sec. from the previous card presentation or you can end it earlier by pressing the [#] mark. The new users added with this function are stored in unoccupied (free) location of the memory and their IDs are unknown.

[13][ID][PIN][#][Card] – Add NORMAL user with ID, PIN and card

The new NORMAL user is registered in the memory at the location indicated by his ID number (ID=000–119). Both, the entered PIN code and presented proximity card are assigned to programmed user. When you want to program only PIN enter: [13][ID][PIN][#][#], when you want to program only card enter: [13][ID][#][Card].

[14][PIN][#] – Add TOGGLE user with PIN

The new TOGGLE user added with this function is stored in unoccupied (free) location of the memory and his ID is unknown.

[15][Card 1][Card 2]...[Card N][#] – Add multiple TOGGLE users with cards

The reader indicates each successful reading of the presented card with an acoustic prompt for the next one to follow. This function will be ended automatically if no card is presented within 20 sec. from the previous card presentation or you can end it manually by pressing [#]. Note, that the new card users added with this function are stored in unoccupied (free) locations of the memory and their IDs are unknown.

[16][ID][PIN][#][Card] – Add TOGGLE user with ID, PIN and card

The new TOGGLE user is registered in the memory at the location indicated by his ID number (ID = 000–119). Both, the entered PIN and card are assigned to him. When you want to program only PIN enter: [16][ID][PIN][#][#], when you want to program only card enter: [16][ID][Card].

[17][PIN][#] – Add TOGGLE LTD user with PIN

The new TOGGLE LTD user is stored in a first unoccupied memory location with entered PIN, his ID number is unknown.

[18][Card 1][Card 2]...[Card N][#] – Add multiple TOGGLE LTD users with cards

The reader indicates each successful reading of the presented card with an acoustic prompt for the next one to follow. This function will be ended automatically if no card is presented within 20 sec. from the previous card presentation or you can end it manually by pressing [#]. Note, that the new users added with this function are stored in unoccupied (free) locations of the memory and their IDs are unknown.

[19][ID][PIN][#][Card] – Add TOGGLE LTD user with ID, PIN and card

The new TOGGLE LTD user is registered in the memory at the location indicated by ID number (ID=000-119). Both, the entered PIN and the presented proximity card are assigned to him. When you want to program only PIN enter: [19][ID][PIN][#][#], when you want to program only card enter: [19][ID][Card].

[20] – Delete all users

Reader deletes all users (cards and PIN-s) so that all user IDs are released and can be programmed anew. The MASTER and INSTALLER users are not deleted with this function.

[21][PIN][#] – Delete a PIN

The reader searches its memory for the entered PIN. Once successful it removes it from the memory, the location previously occupied by this PIN is released. This command removes only PIN, if the user had card he still can use it.

[22][Card] – Delete a card

The reader searches its memory for the presented card. Once successful it removes it from the memory, the location previously occupied by this card is released. This command removes only card, if the user had PIN he still can use it.

[23][ID] – Delete a user with given ID

A user with entered ID is deleted (both his card and his PIN are removed), a new user can be programmed to use this ID index.

[24][YYMMDDhhmm] – Setting date and time



Where: YY – year (two last digits), MM – month (1-12), DD – day (1-31), hh – hour (00-23), mm – minutes (00-59)

[#] – Exit from User Programming Mode

After exit from the User Programming mode reader returns to the either armed or disarmed mode it was in earlier (before programming).



Programming Examples

Example 1: Add a new TOGGLE LTD user with a card; programming sequence: [1][8][Card][#] or [1][8][Card][Wait ~20s or press [#]]

- Read your MASTER card
- The reader enters User Programming mode (LED OPEN  is on and LED STATUS  is on and red)
- Press [1][8]
- LED SYSTEM  starts flashing
- Present a card which you want assign for a new TOGGLE LTD user
- Press [#], command is completed

The reader has completed programming function, however, it has not left User Programming mode so that now you may use your next desired programming command.

Example 2: Delete a user with ID=45; programming sequence: [2][3][0][4][5]

- Read your MASTER card
- The reader enters User Programming mode (LED OPEN  is on and its LED STATUS  is on and red)
- Press [2][3]
- LED SYSTEM  starts flashing

- Press [0]
- Press [4]
- Press [5]
- Press [#], command is completed

The user with ID=45 has been deleted, reader still remains in User Programming mode, so that you may use your next desired programming command.

9 . P R O G R A M M I N G F R O M P C

The PRT-MF can be fully programmed from the PC strait through ordinary COM port (RS232) or via dedicated RUD-1 interface (USB port). In both cases the RARC program is required.

9.1.1. Programming via RS232 COM port

In this scenario connection between programmed reader and PC requires four wires: GND, RXD, TXD and RTS as presented on the drawing below however the programmed device must be supplied from the external source of power. In order to start communication between RARC and reader click on *Connection/Connect...* and follow instruction on the screen.

Note: For programming purpose CLK, DTA and RTS lines must be disconnected from signals/devices they were earlier connected.

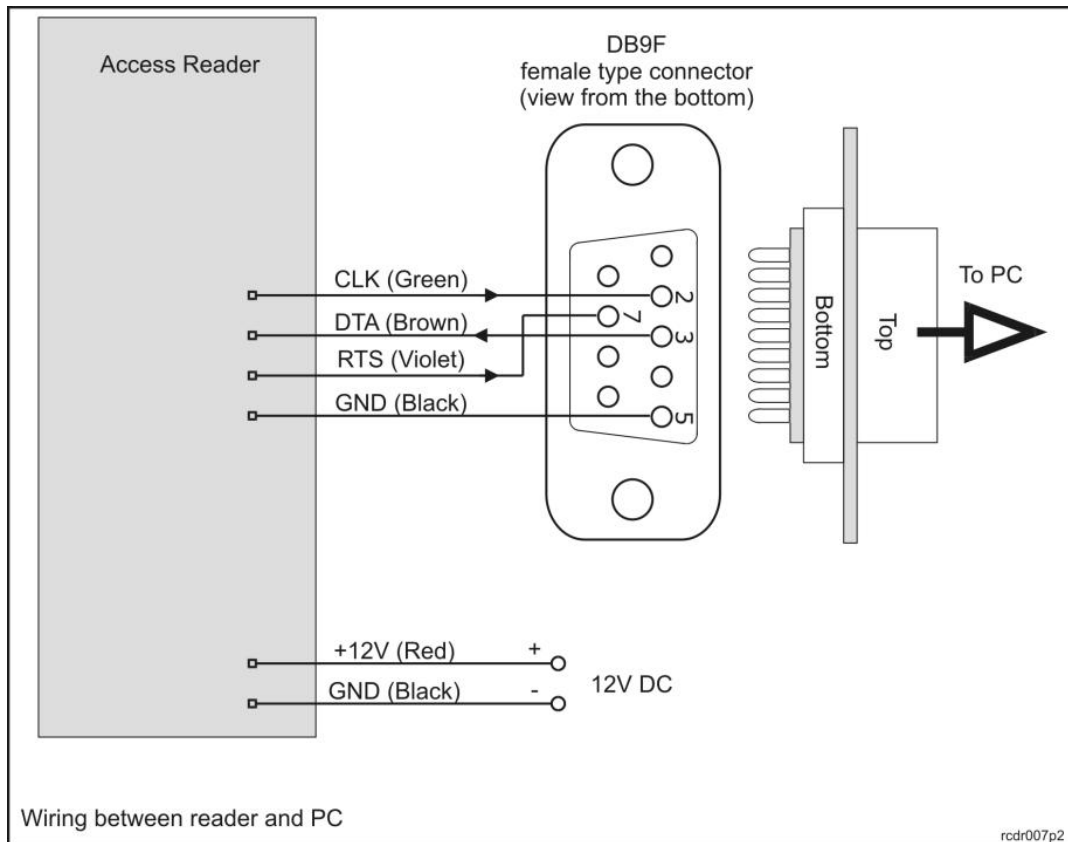

9.2. PROGRAMMING VIA RUD-1 INTERFACE

In this scenario connection between programmed reader and the PC is made through dedicated RUD-1 interface which is also used to supply programmed device (no extra source of power is required). Once the reader is connected to PC start RARC program, select proper COM port, click on *Connection/Connect...* button and follow instructions on the screen.

Note: RUD-1 interface can be used for both: reader programming and upgrade of its firmware.

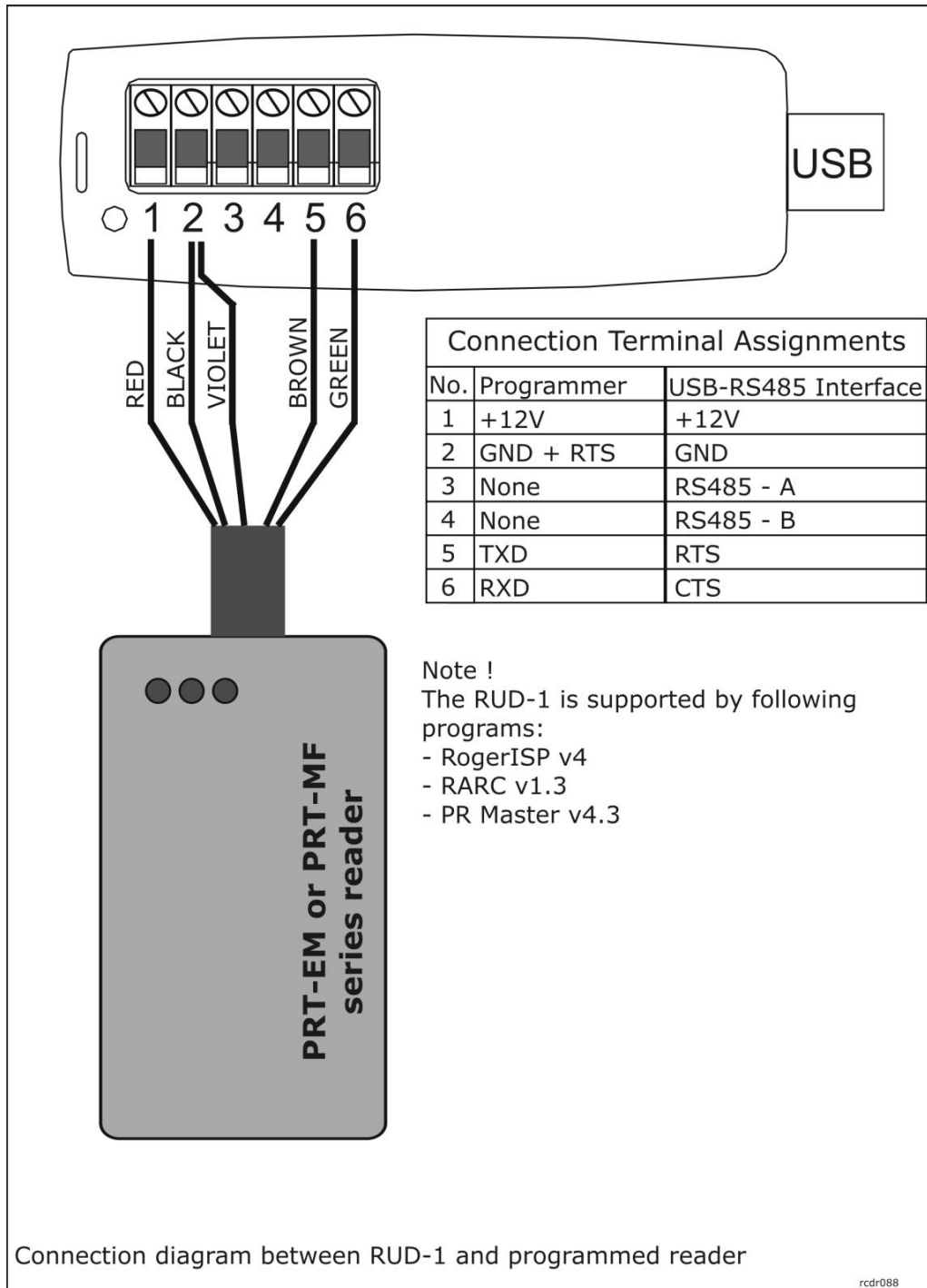

9.3. FIRMWARE UPGRADE

Although the factory new reader is programmed with the latest firmware version available, it can be later upgraded with a newer one. Roger design team continuously develops functionality enhancements for the products allowing new firmware versions to be released periodically (for every new firmware version available check our www.roger.pl website). Our customers are kindly advised to register at the website so that Roger can send information as soon as new firmware versions will be ready for download.

Firmware can be uploaded to reader via ordinary RS232 COM port or RUD-1 (USB) interface. In both cases RogerISP 4 program is required.

Note: Once the firmware upgrade is accomplished but programmed device doesn't work at all it can be that wrong firmware has been uploaded to device or upgrade wasn't successful. In this case you can try to upgrade firmware once again.

9.3.1. Firmware upgrade via RS232 COM port

- Connect reader to PC's COM port as explained in section 9.1.1
- Power up the reader (device must be supplied from external source of power)
- Place jumper on FDM contacts
- Restart the reader (short RST contacts for while)
- Start RogerISP program and select COM port you have connected the reader
- Click on *Erase* command, RARC program will detect device type and select proper communication protocol (you should see *P89 series duplex, 19200* in the bottom of the RogerISP program), finally old firmware will be erased
- In *Firmware* text window select file with the new firmware (file extension: HEX) then click on *Program*
- Once the new firmware is uploaded, remove jumper from FDM contacts and restart the reader (disconnect power for while or short RST contacts for a moment)
- Re-configure the reader anew either manually or from PC

9.3.2. Firmware upgrade via RUD-1 interface

- Connect reader to RUD-1 interface as explained in section 9.2
- Place jumper on FDM contacts
- Start RogerISP program and select COM port with the RUD-1
- Click on *Erase* command, RARC program will detect device type and select proper communication protocol (you should see *P89 series duplex, 19200* in the bottom of the RogerISP program), finally old firmware will be erased
- In *Firmware* text window select file with the new firmware (file extension: HEX) then click on *Program*
- Once the new firmware is uploaded, remove jumper from FDM contacts and restart the reader
- Re-configure the reader anew either manually or from PC

Location of programming jumpers in various PRT-MF series readers

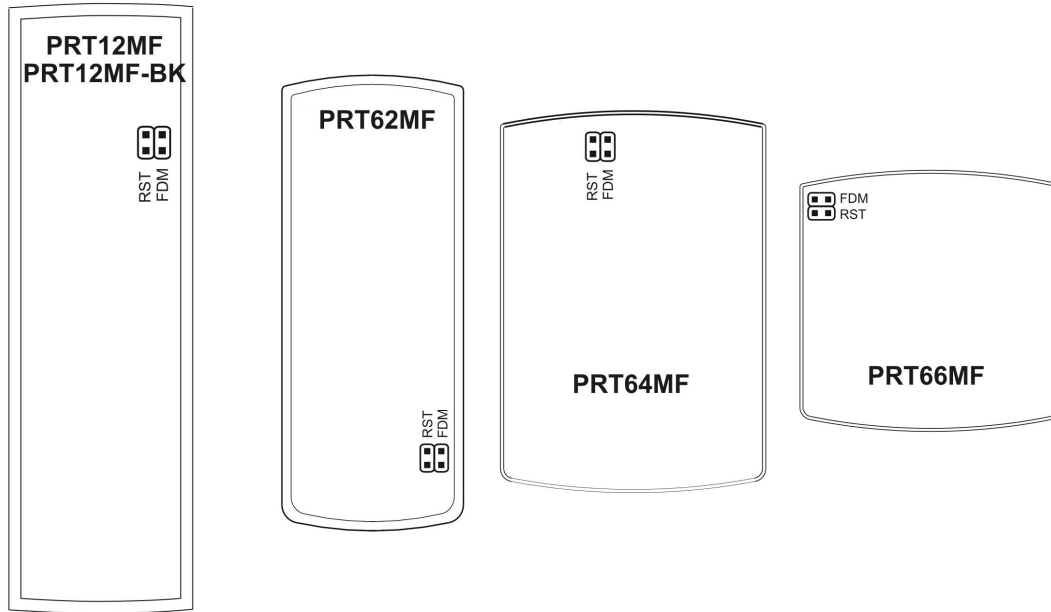



Jumpers:
RST - restart jumper
FDM - firmware download mode jumper

rcdr083

10. INSTALLATION GUIDELINES

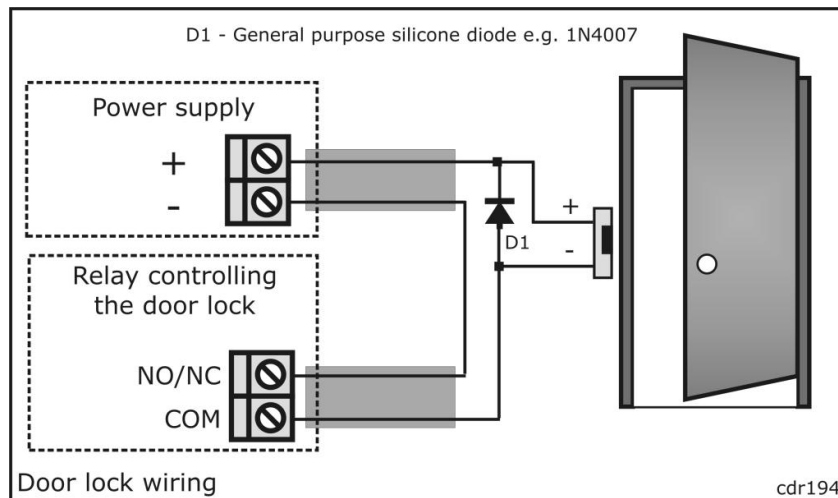
- Reader should be installed in such a way to assure physical access to the connection cable and to the programming jumpers as well.
- Before the reader will be mounted in desired location we suggest to configure it for requested operating mode and if required to program the MASTER and INSTALLER users.
- Any proximity Mifare type card can be programmed as MASTER or INSTALLER card, manufacturer of the reader does not supply the unit with any cards.
- When lost or stolen a new MASTER and INSTALLER cards (PIN-s) can be reprogrammed to the reader anew.
- When the reader has been set for **Terminal Mode** (online unit connected to the host controller), programming of MASTER and INSTALLER users can be skipped.
- A new factory delivered unit is configured for **RACS address ID=0**.
- The PRT-MF reader should be mounted near the supervised door on a vertical piece of supporting structure.
- Disconnect power supply before making any electrical connections.
- Be aware that when installing the reader directly on the metal type surface will reduce card reading distance.
- For installations on a metal surface you can place a non-metallic 10 mm thick spacer (a plastic/plaster plate etc.) between the reader and the supporting structure.
- For installations with two readers to be mounted on the opposite sides of the same wall and aligned along the same geometrical axis, place a metal plate between them and make sure none of two readers has direct contact with it (allow min. 10 mm space). Nevertheless the reading distance will be reduced.
- For best results mount the proximity readers at least 0.5 m apart.
- When using separate power supply sources, short all power supply negatives (ground).
- Roger recommends grounding of the negative power supply lead (only at one point).
- With its relatively weak electromagnetic field generation, reader should not cause any harmful interference to operation of other equipment. However, its card reading performance can be affected by other interference generating devices, esp. radio waves emitting equipment etc.
- If card reading performance of the reader deteriorates (e.g. reduced reading range or incorrect readings) consider reinstallation in a new location.
- Always connect a general purpose, silicon diode (e.g. 1N4007) in parallel to a door lock, locate diode as close as possible to the lock.



Pig-tail Cable Assignments (valid for readers without screw terminals)				
Wire Color	Label	Standalone Modes (Offline Modes)		Terminal Modes (Online Modes)
		Simple Standalone Mode	Full Standalone Mode	
Green	CLK	Configured as input or output, programmable function	CLOCK communication line	DATA 0 line for Wiegand, CLOCK for Magstripe and RACS, TXD for RS232
Brown	DTA	Configured as input or output, programmable function	DATA communication line	DATA 1 line for Wiegand, DATA for Magstripe and RACS, RXD for RS232
Yellow	IN1	Input line, programmable function		In Wiegand and Magstripe this line controls LED OPEN  . Line is active when shorted to ground
Blue	IN2	Input line, programmable function		In Wiegand and Magstripe this line controls internal sunder of the reader. Line is active when shorted to ground
Gray-Pink	Relay NC	Relay output 1.5A 24V DC/AC, programmable function		Not used
Red-Blue	Relay COM			
Pink	Relay NO			
Violet	RTS	RTS line for RS232		
Red	+12V	Supply input plus		
Black	GND	Supply input minus, also reference ground for RS232		
Grey	TAMP	Tamper switch contacts, normally closed, isolated, IP67, 24V/50mA. Contact becomes open when unit is detached from the place of installation or upper part of enclosure is open.		
White				

Note: The PRT12MF, PRT12MF-BK and PRT62MF are not equipped with built-in relay output and therefore Relay NO/NC/COM terminals/connectors doesn't exist on these products.

Technical Specification	
Supply voltage	10-15 VDC
Current consumption	PRT12MF: 85mA PRT12MF-BK: 65mA PRT62MF: 65mA PRT64MF: 85mA PRT66MF: 65 mA
Anti-sabotage protection (Tamper)	NC contact, 50mA/24V, IP67
REL1 built-in relay output	NO/NC/COM dry contact, 1.5A/30V
CLK and DTA transistor outputs sink current	50mA/15V
Reading distance	Up to 6 cm for ISO cards (depends on type of card) Note: Reading distance is defined for good quality ISO size proximity cards placed in optimal position against the reader. For all PRT-MF readers the optimal card position is in the front of the reader (card surface parallel to front of the reader).
Anti-collision	Yes
Proximity cards	ISO/IEC 14443A and Mifare
Communication distance	Between ACU and PRT reader in ONLINE mode: max. 150 m Between main PRT reader and second PRT reader: max. 150 m Between main PRT reader and XM-2 extension module: max. 150 m
Environmental class according to EN 50131-1	PRT12MF/PRT12MF-BK: Class IV PRT62MF: Class IV PRT64MF: Class IV PRT66MF: Class IV Class IV , outdoor-general, temperature: -25°C- +60°C, relative humidity: 10 to 95% (non condensing)
Dimensions	PRT12MF/PRT12MF-BK: 150.5 X 46 X 23 mm PRT62MF: 100 X 45 X 25 mm PRT64MF: 115 X 80 X 35 mm PRT66MF: 85 X 85 X 27 mm
Weight	PRT12MF/PRT12MF-BK: 150g PRT62MF: 100g PRT64MF: 120g PRT66MF: 120g
Approvals	CE

Ordering Codes	
PRT12MF	Outdoor proximity reader with keypad, laser engraved long durability silicon rubber keypad, two function keys, dark grey ABS enclosure, pig-tail cable
PRT12MF-BK	The same as PRT12MF but without keypad
PRT62MF	Outdoor, miniature proximity reader without keypad, dark gray ABS enclosure, pig-tail cable
PRT64MF	Outdoor proximity reader with keypad, laser engraved long durability silicon rubber keypad, two function keys, dark grey ABS enclosure, screw terminals, pig-tail cable as option
PRT66MF	Outdoor proximity reader without keypad, dark gray ABS enclosure, screws terminals, pig-tail cable as option
RM-2	Relay module with plastic box, two relays with single NO/NC contact 1.5A/24V rated
RM-2-BRD	RM-2 electronic module (board) only
XM-2	Input/output addressable extension module with plastic box, digital communication with reader, two NO/NC inputs and two relay outputs, each relay offers single NO/NC contact 1.5A/24V rated
XM-2 PCB	XM-2 electronic module (board) only
PE-1	Plastic enclosure for XM-2/RM-2 modules

Product History			
Electronic module	Firmware	Date	Description
v1.0	fv1.20	11/12/07	The initial product version
v1.0	fv1.23	11/02/08	No change
v1.0	fv1.24	17/03/08	Time range for Door Unlock Time and Door Open Timeout extended to 99 minutes. Programming functions [51] and [52] removed and replaced by functions [71] and [72]
v1.0	fv1.25	19/05/08	CLK line operation in Simple Standalone Mode corrected; Door Bell indication on internal buzzer and output corrected
v1.0	fv1.29	16/02/2010	Extended functions in standalone mode and EPSO protocol. Adjustment of keypad backlight and buzzer loudness level available.

User List				
Reader name:		Reader location:		
ID	Card code	PIN	Type	User Name
None			MASTER	
None			INSTALLER	

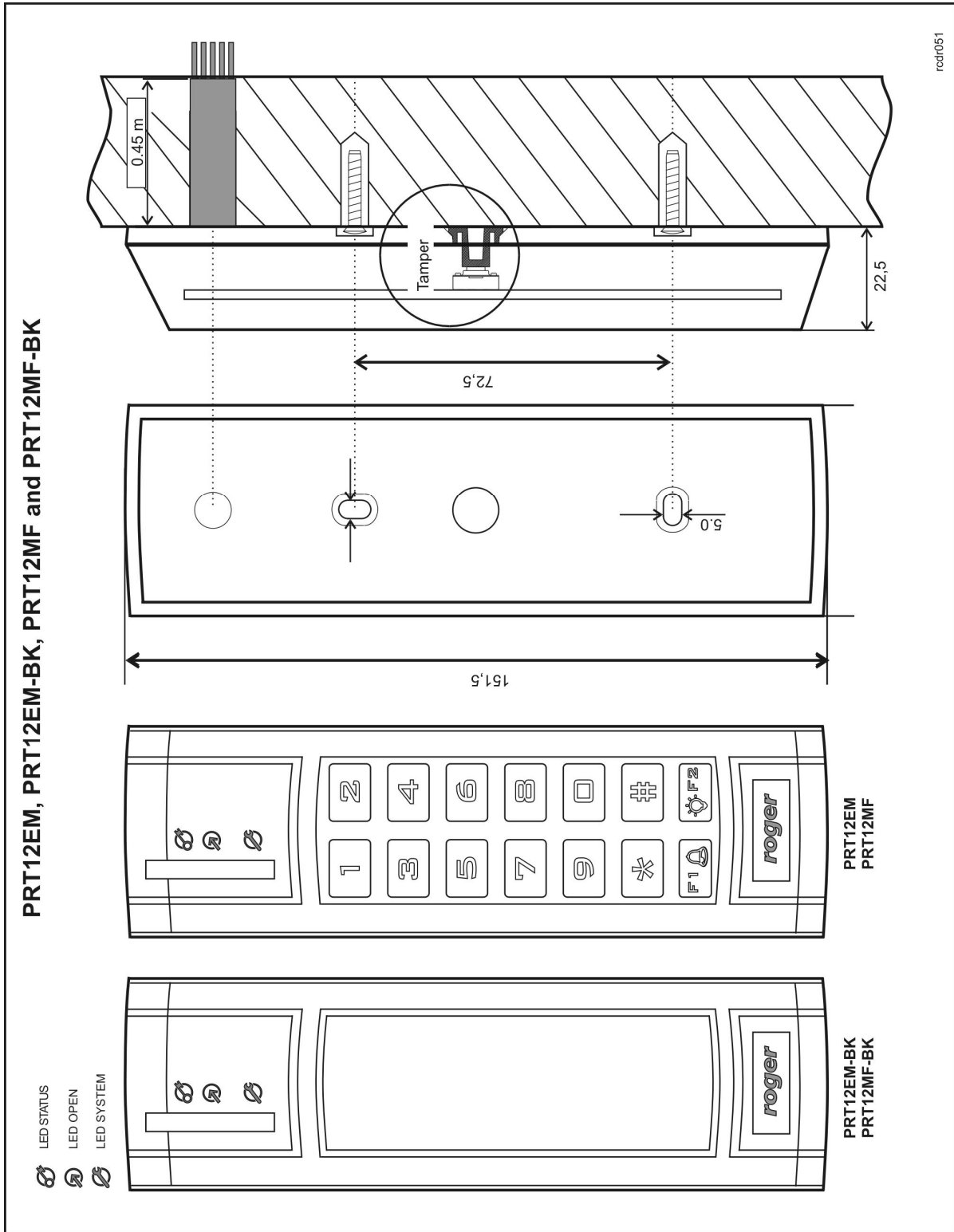

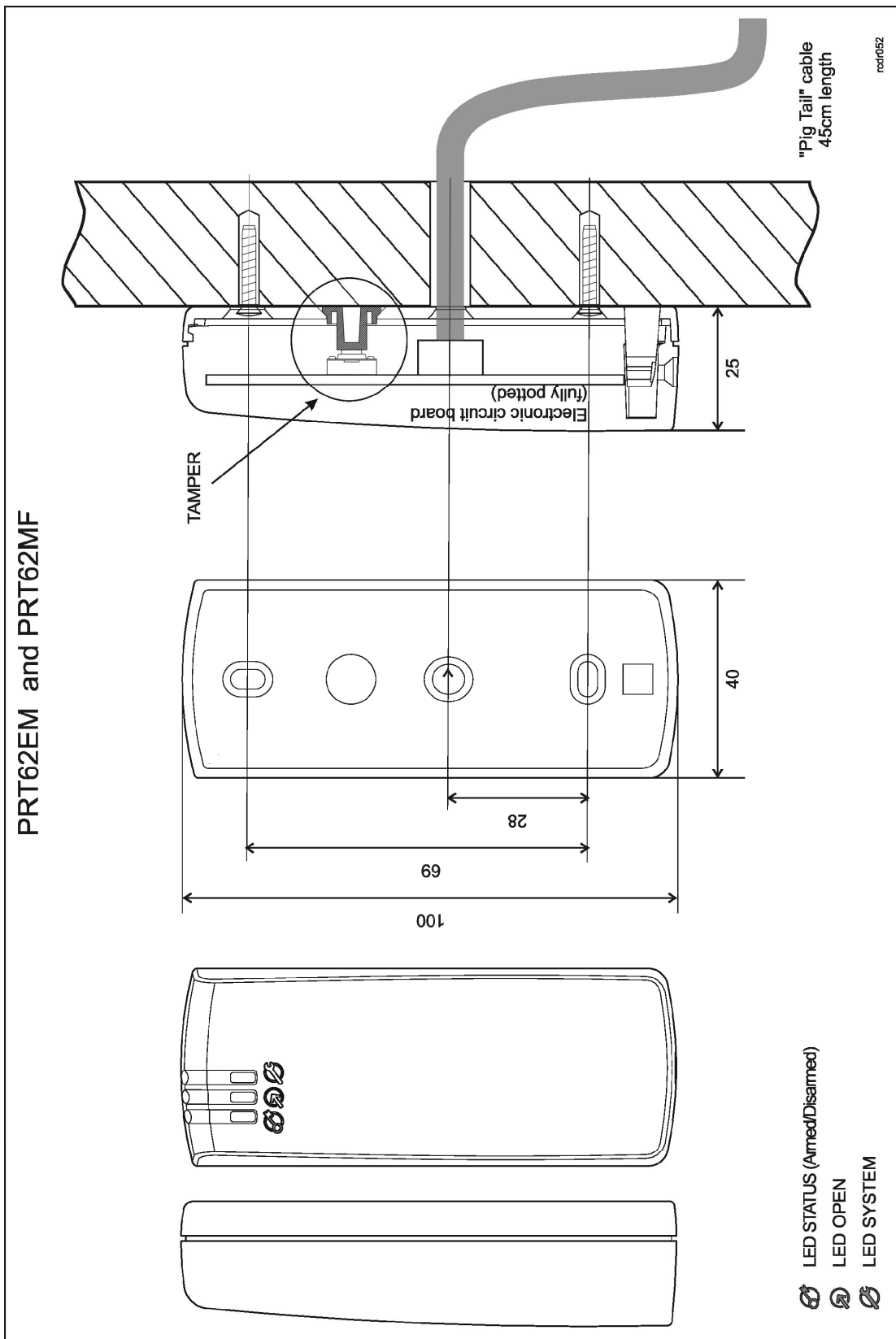

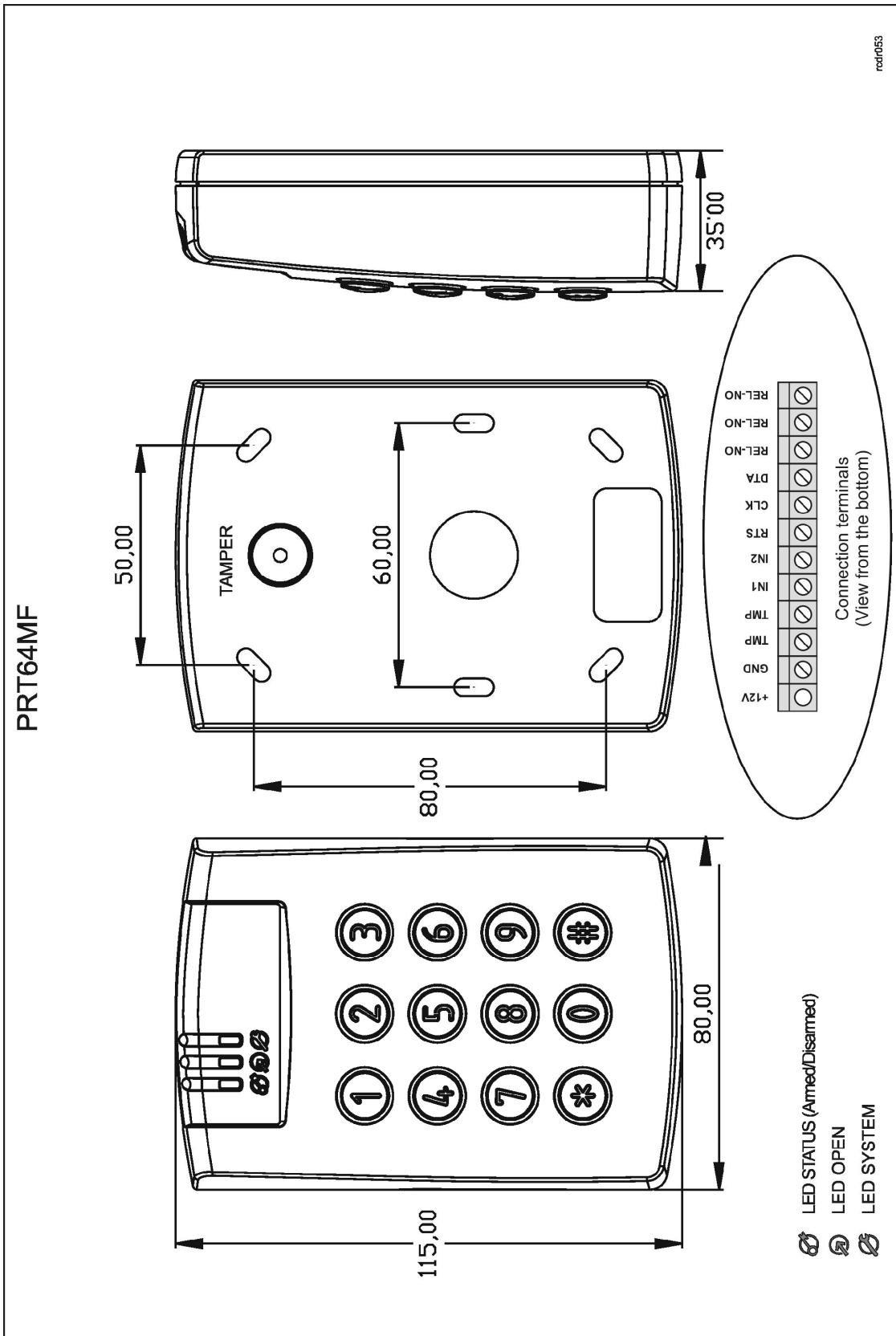

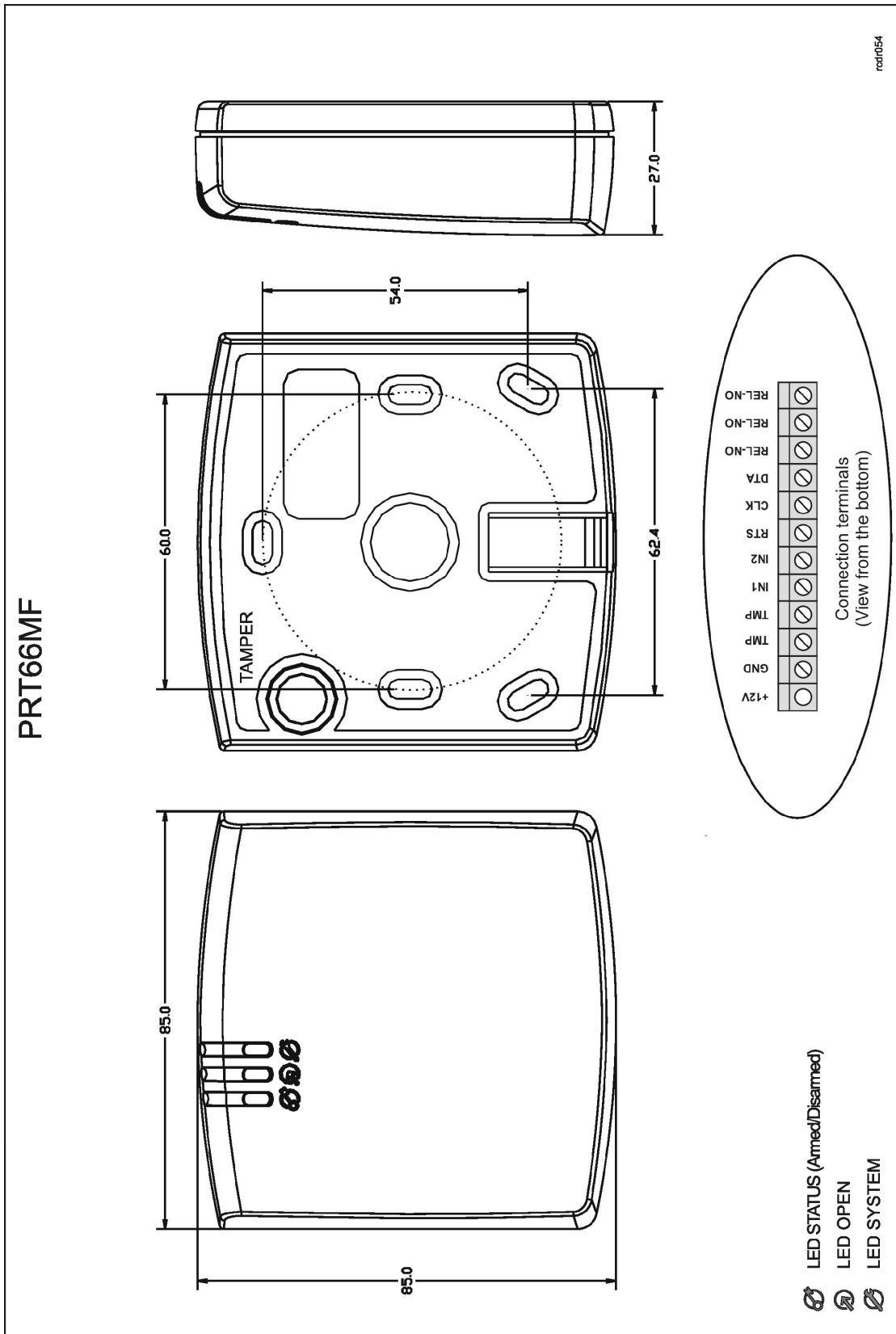

PRT-EM and PRT-MF series readers operation in Online Mode

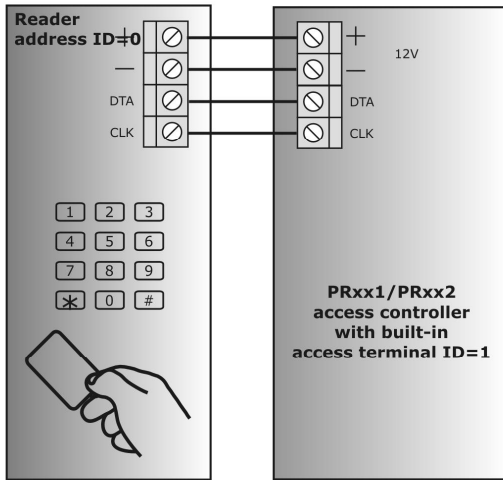

Connection to PRxx1/PRxx2 series access controller with built-in ID1 terminal

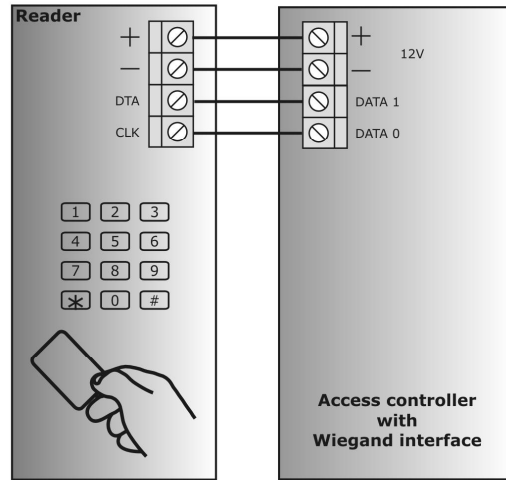

Connection to access control unit with Wiegand interface

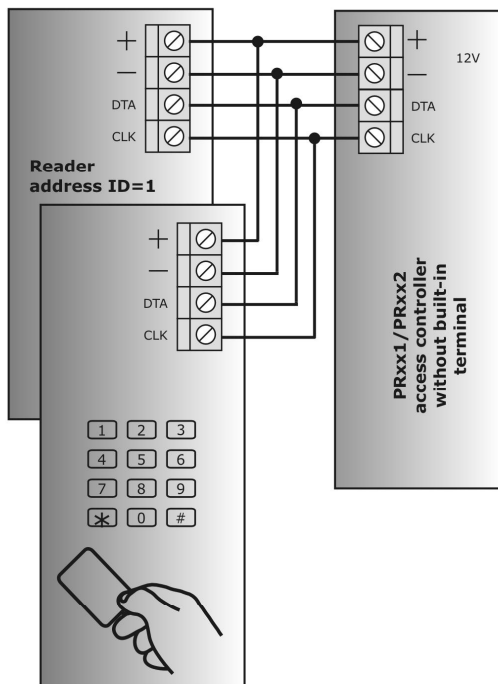

Connection to PRxx1/PRxx2 series access controllers (two-way door control)

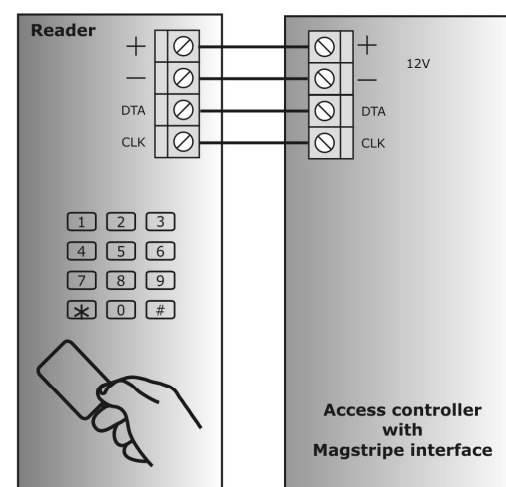

Connection to access control unit with Magstripe interface

rcdr060

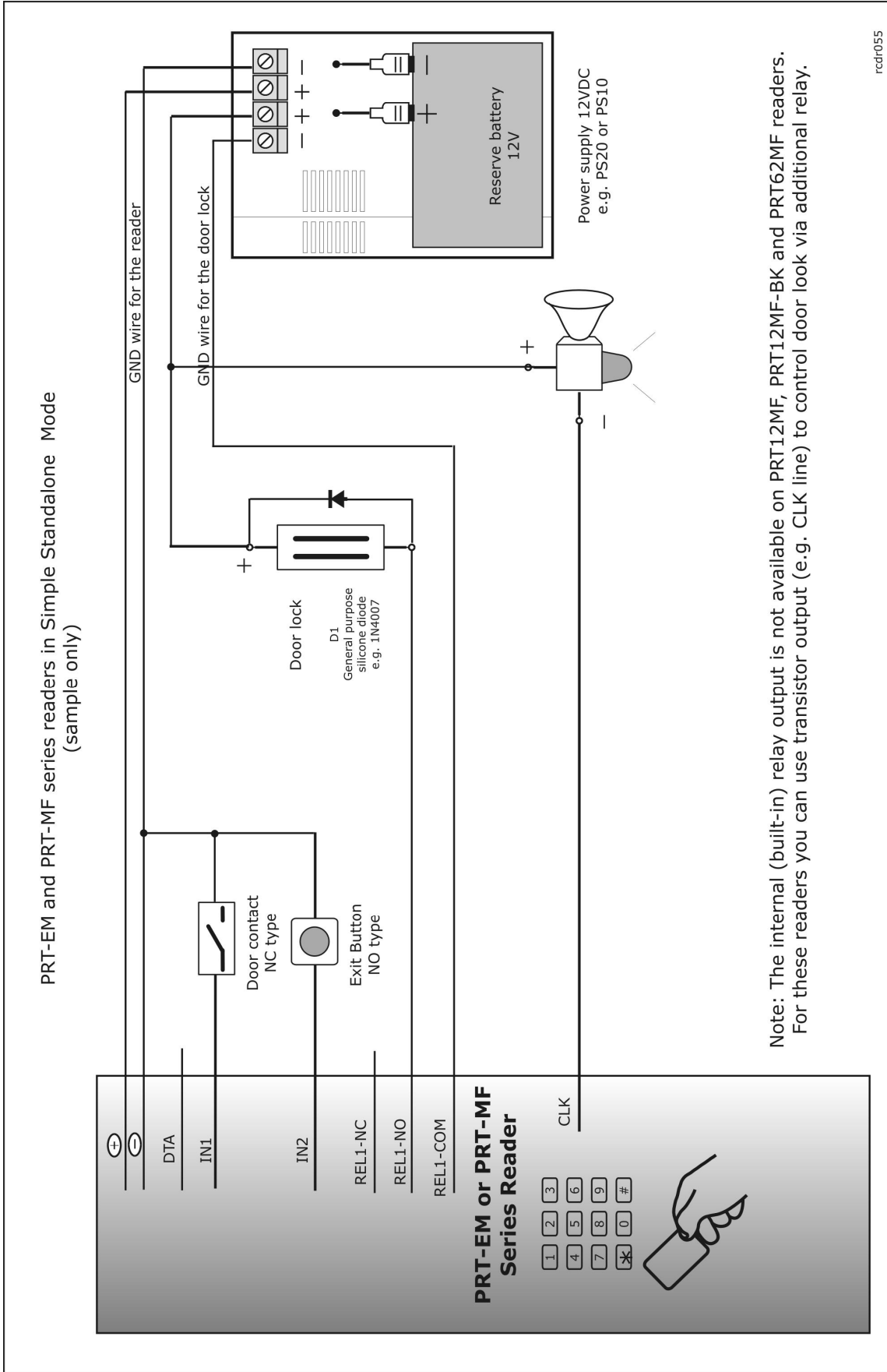

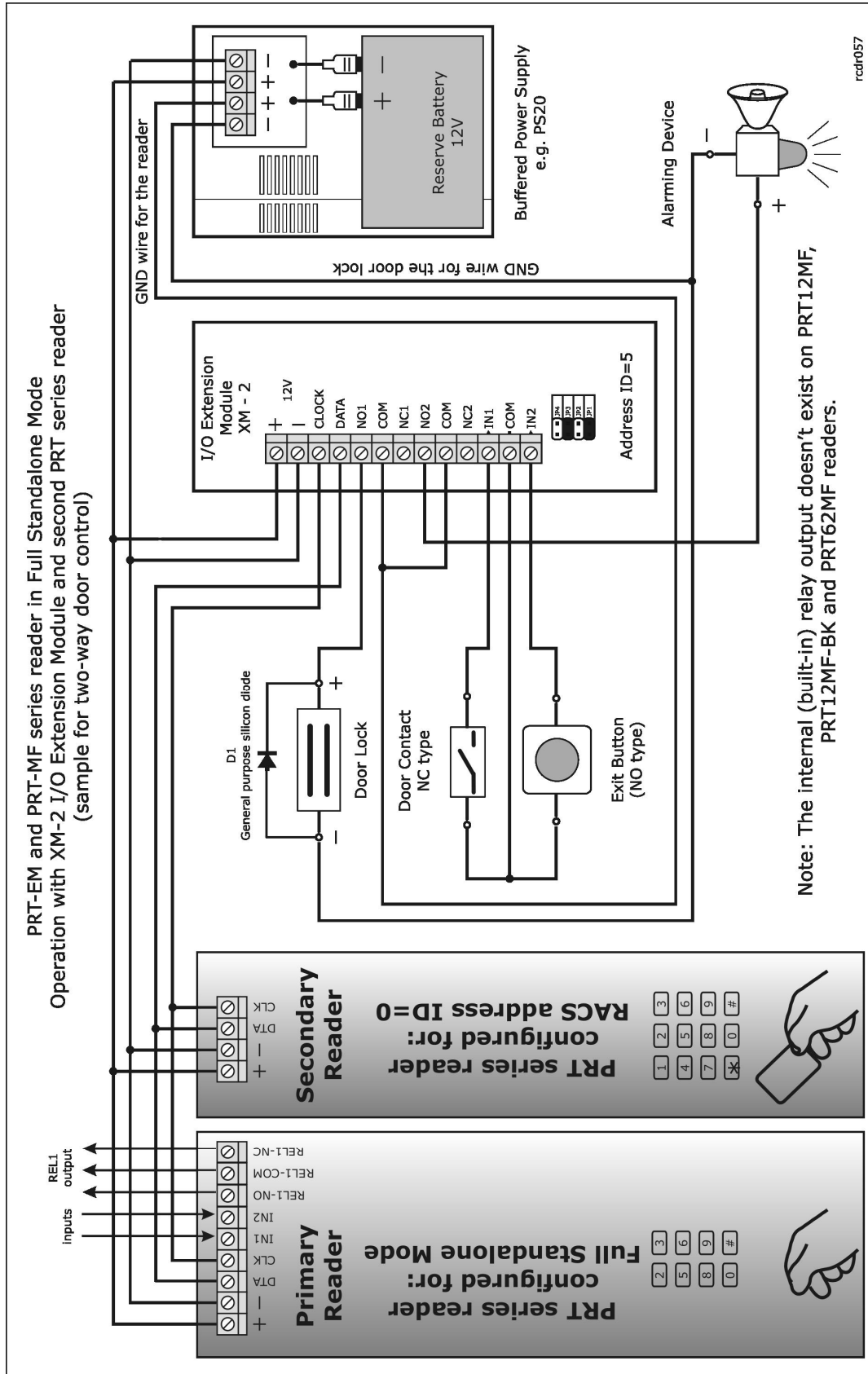



The symbol of a crossed-through waste bin on wheels means that the product must be disposed of at a separate collection point. This also applies to the product and all accessories marked with this symbol. Products labeled as such must not be disposed of with normal household waste, but should be taken to a collection point for recycling electrical and electronic equipment. Recycling helps to reduce the consumption of raw materials, thus protecting the environment.

Contact**Roger sp.j.****82-400 Sztum****Gościszewo 59****Tel.: +48 55 272 0132****Fax: +48 55 272 0133****e-mail: biuro@roger.pl****Internet: www.roger.pl**