

JA-111H Bus module for the connection of a detector

This product is a component of the **JABLOTRON JA-100** system. It is designed to be installed inside a standard wire detector (with contact outputs) and it provides a power supply for the detector. The module has a status reaction (reports its activation and deactivation). Should be installed by a trained technician with a valid certificate issued by authorized distributor.

Installation

1. Install the module at a suitable place in the detector.
2. Connect the wires to the detector (according to Fig. 1). The connection wires cannot be extended.

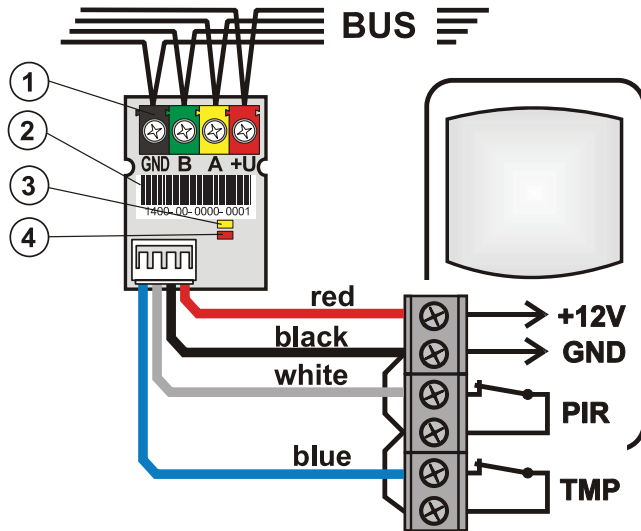

Figure: 1 – bus terminal board; 2 – production code; 3 – yellow fault indicator; 4 – red indicator is used to indicate activation of alarm or tamper input with a flash

Wire colour	label	function
red	+ 12 V	Connected detector power supply
black	GND	Common wire
white	INP	Alarm input
blue	TMP	Tamper input

3. Connect the bus cable.

When connecting the module to the system bus, always switch the power off.



The power consumption of the connected detector must not exceed 50mA (the module power supply output is not protected against overloading).

4. Proceed according to the control panel installation manual. Basic procedure:
 - a. When the device is switched on, the yellow LED (3) starts flashing repeatedly to indicate that the module has not been enrolled into the system.
 - b. Go to the **F-Link** program, select the required position in the **Devices** window and launch the enrollment mode by clicking on **Enroll** option.
 - c. Press the tamper contact in the detector (or briefly connect the blue and black module wires together) – the module is thus enrolled and the yellow LED indicator goes off.
5. Close the cover of the detector with the installed module.

Internal settings of the module

The module properties can be set in the **Devices** window of the F-link program. Use the **Internal settings** option at the detector position to open a dialog window where you can set:

Signal input: Disabled / Enabled – the INP input can be disabled completely.

INP input reaction delay – A time filter for increasing false alarm immunity – it can be set from 0.1s to 300s to define how long the INP input must be active in order to be activated in the control panel.

Inverted input reaction: it is NC reaction by default but it can be changed to NO reaction.

Inverted TMP reaction: it is an NC reaction by default but it can be changed to NO reaction.

LED indication enabled: Allows disable activation of red LED indication.



The manufacturer only guarantees correct functioning of the module. However, they cannot guarantee the correct functioning of the connected detector. We therefore recommend using Jablotron JA-100 bus detectors.

Technical specifications

Power	from control panel bus 12 V (9...15 V)
Current consumption in standby mode*	5 mA
Current consumption for cable choice*	5 mA
Maximum allowed current of the connected detector	50 mA
Dimensions	22 x 27 x 14 mm
Classification	Grade II
according to	EN 50131-1, EN 50131-3
Operational environment according to	EN 50131-1 II. Indoor general
Operating temperature range	-10 to +40 °C
Also complies with	EN 50130-4, EN 55022

*the consumption of the powered detector has to be added to the system power backup calculation

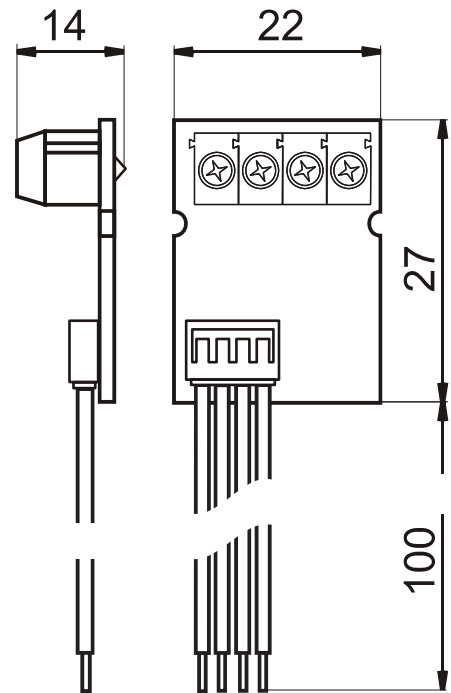

JABLOTRON ALARMS a.s. hereby declares that the JA-111H module is in compliance with the essential requirements and other relevant provisions of Directive 1999/5/EC. The original of the conformity assessment can be found at www.jablotron.com - Technical Support section



Note: Although this product does not contain any harmful materials we suggest you return the product to the dealer or directly to the producer after use. For more detailed information visit www.jablotron.com.